

radicon 

An Elecon Group Company

Series G Industrial Reducer

G

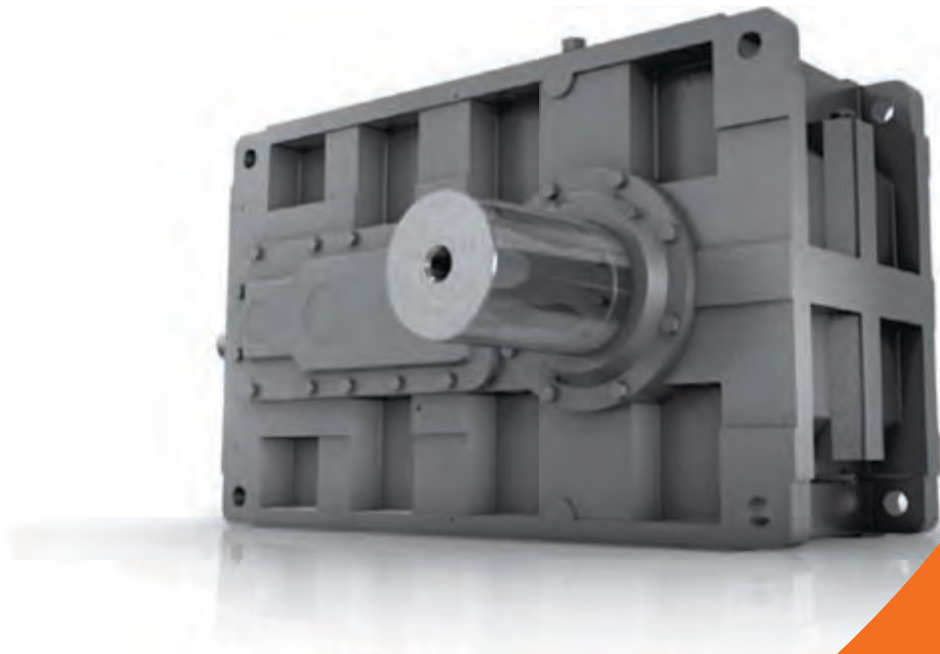

# SERIES G

---



General Description _____	1
Unit Designations _____	2
Design Features _____	3
Explanation and use of Ratings and Service Factors _____	5
Selection Procedure _____	8
Unit Handings and Shaft Rotations _____	10
Installation & Maintenance _____	13
Fault Diagnosis _____	18
Lubrication _____	19
Standard Shaft Sealing Arrangements _____	22
Input Shaft Options _____	23
Output Shaft Options _____	24
Output Bore Options _____	25
<b>REDUCER</b>	
Overhung & Axial Loads on Shafts _____	28
Agitator Applications _____	30
<b>Parallel Shaft Units</b>	
Moments of Inertia _____	34
Exact Ratios _____	35
Mechanical Ratings - Input Power / Output Torque _____	36
Thermal Ratings _____	40
Dimension Sheets - Speed Reducers _____	42
Fan Cooling _____	50
<b>Right Angle Shaft Units</b>	
Moments of Inertia _____	53
Exact Ratios _____	54
Mechanical Ratings - Input Power / Output Torque _____	55
Thermal Ratings _____	59
Dimension Sheets - Speed Reducers _____	60
Fan Cooling _____	61
Hollow Output Shaft with Shrink Disk _____	73
Keyed Sleeves _____	74
Cooling Coil Connections _____	75
Backstops _____	76
Torque Arm _____	77
<b>MOTORIZED</b>	
Motorized Dimension _____	79
Shipping Specification _____	81

# SERIES G

## GENERAL DESCRIPTION

### Series G

Series G gear units are available in parallel shaft helical units and right angle shaft bevel/helical units in double, triple and quadruple reduction gear stages.

The modular design and construction of the Series G offers many engineering and performance benefits including a high degree of interchangeability of parts and sub assemblies. This in turn provides considerable economies of production while maintaining the highest standard of component integrity.

Adding to the range of power transmission geared motors this product takes advantage of our many years of accumulated design expertise together with the use of high quality materials and components. The end result is a series of speed reducing gear units offering high load carrying capacities, increased efficiency, quiet running and reliability.

### The Range Includes

- 8 sizes of units with a ratio coverage of 6.3:1 to 315:1.
- Parallel shaft helical units and Right angle bevel/helical units.

### Design Features Include

- Profile ground helical gears / hard finished spiral bevel gears.
- High level of surface finish for quiet running.
- Units can be offered in horizontal mounting positions or alternatively vertical mounting.
- Specially designed units are available for heavy duty agitator applications.
- All units are also available with a hollow bore for output shaft mounting. Output bores are connected by a shrink disk or can be supplied with a keyed sleeve.
- Backstops can be fitted to all Series G units when required to operate in non-reversing drives.

As improvements in design are being made continually this specification is not to be regarded as binding in detail and drawings and capacities are subject to alteration without notice. Certified drawings will be sent on request.

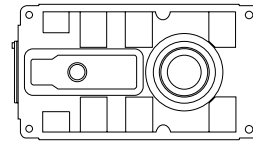

Parallel shaft unit

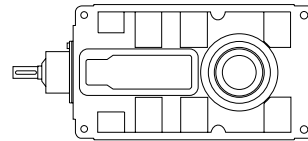

Right angle shaft unit

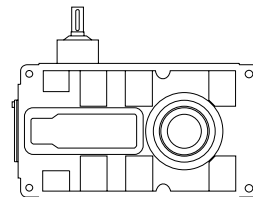

Type 'J' right angle shaft unit

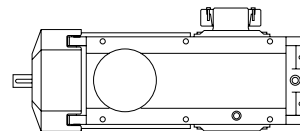

Right angle shaft unit with mechanical fan and hollow output shaft with shrink disc

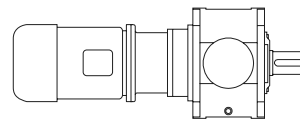

Parallel shaft unit with a lantern housing coupling and motor

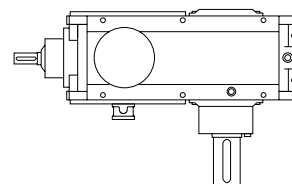

Right angle heavy duty agitator unit

# SERIES G

## UNIT DESIGNATIONS

\* THIS PAGE MAY BE PHOTOCOPIED ALLOWING THE CUSTOMER TO ENTER THEIR ORDER

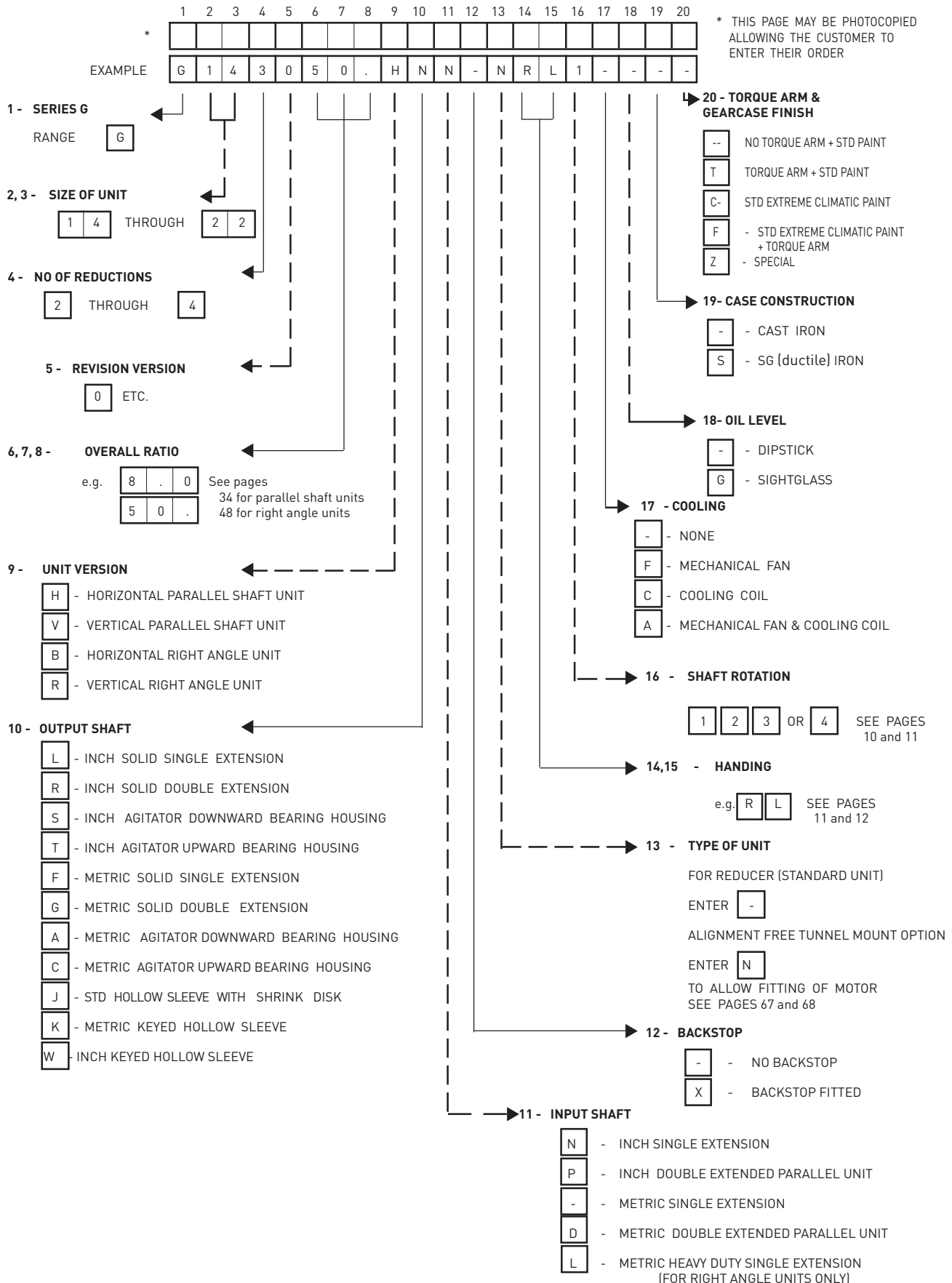

### Shaft Mounted Units

Shaft mounted units can be mounted on the driven machine shaft extension and connected to the foundation by a torque arm, supplied as an optional extra.

Additionally, unit feet are available for mounting on a baseplate with motor and coupling, the complete assembly being mounted on the driven machine shaft extension and connected to the foundation by a torque arm.

Shaft mounted units are fitted with a 'shrink disk' device to provide positive clamping on the driven machine shaft extension.

Shaft mounted units with keyed sleeves may also be supplied for fitting on to a keyed shaft.

### Motorized Gear Units

Gear units are available as standard assemblies comprising IEC standard metric (B5) flanged and NEMA C-Face motors directly mounted on the gearcase input shaft housings by adaptors. Motor and gear unit shafts are connected by flexible couplings.

### Baseplates

Standard baseplates can be supplied for units with parallel or right angle shafts. Assemblies comprise of gear units and foot mounted motors correctly aligned in manufacture and connected by our couplings. Coupling guards are fitted.

Baseplates for right angle shaft gear units are designed for use with either foot or shaft mounted arrangements, and provision is made for attaching torque arms where required.

Designs provide ample stiffness to prevent distortion under load. Full details are available from our Application Engineers.

### Backstops

Externally mounted Backstops can be fitted to all Series G gear units, when required to operate in non-reversing drives. They are located on the helical pinion shaft and have adequate capacities to deal with full rated torques. All backstops are centrifugal lift off type. Changing the direction of locking rotation is a simple operation. If required, a torque limiting backstop with controllable tension release can be fitted to all units (consult our Application Engineers).

### Preservation / Protection

Series G gear units are shipped without oil.

Prior to shipping they are test run with a rust preventative oil giving adequate protection to internal parts for a period of six months covering normal transport and covered storage.

Shaft extensions and hollow output shafts are protected with a rust inhibitor which is protection against sea water and suitable for under-cover storage up to 12 months.

Note: Where gear units are to operate in abnormal conditions, or where they are to stand for long periods without running, e.g. in plant installation, we must be notified so that suitable protective arrangements can be made.

## DESIGN FEATURES

### Gears

High quality alloy case hardening materials provide long life wear resistance and fatigue strength.

Profile ground single helical gears and hard finished spiral bevel gears ensure high standards of accuracy, Surface finish and quiet running characteristics. Helical gears are fitted in parallel shaft units. Units with shafts at right angles incorporate spiral bevel and helical gears.

### Gearcases

Standard gearcases are of rigid cast iron construction with modern styling, special cases can be supplied as SG (ductile) iron or fabricated steel.

Horizontal split case design for ease of maintenance.

Gearcase design using finite element analysis to give high strength to weight ratio.

Inspection cover provided for viewing gear contacts.

Oil level dipstick, ventilator and drain plugs are installed.

With an option to install an oil level sight glass.

### Gearcase Finish

Gearcase housings are shot blasted prior to painting.

Standard Paint System - Alkyd enamel.

Optional Paint System for Extreme Climatic and Environmental Conditions - Two part epoxy.

Both paint systems are resistant to dilute acids and alkalis, oils and solvents, sea water and temperatures up to 280°F.

### External Dimensions

Shaft extensions are to inch or metric dimensions. Fasteners are metric.

### Lubrication

Lubrication in most instances is by the transfer of oil by gears dipping in the sumps of gear unit bases. Where high pitch line speeds could cause churning of the lubricant. Spray lubrication is necessary where shown and complete systems can be supplied when required.

The unit oil grade and change period will be stamped on the nameplate. The change period will be 6 months for mineral oil based lubricants and 18 months for synthetic oil based lubricants. These figures assume a sump temperature of 230°F. Oil change periods can be extended for lower sump temperatures see installation and maintenance leaflet.

Units are provided with a dipstick, ventilator and drain plugs.

### Cooling

Depending on the application standard gear units are cooled by:-

Normal heat dissipation by convection from external surfaces.

Mechanical fan fitted to high speed shaft.

Cooling water coil fitted in gear unit base.

Fan and cooling coil.

Separate oil cooler incorporated in forced lubrication system.

As improvements in design are being made continually this specification is not to be regarded as binding in detail and drawings and capacities are subject to alteration without notice. Certified drawings will be sent on request.

## EXPLANATION AND USE OF RATINGS AND ASSOCIATED RATING FACTORS

Gear unit selection is made by comparing actual loads with catalog ratings. Gear ratings are based upon DIN standards. Catalog ratings are based on a standard set of loading conditions, whereas actual load conditions vary according to type of application. Service Factors are therefore used to calculate an equivalent load to compare with catalog ratings. i.e. Equivalent Load = Actual Load x Service Factor

Mechanical and Thermal Service Factor must be considered:- Mechanical Service Factors Fm and Fs  
Thermal Service Factors Ft, Fd, Fh and Fv

### Mechanical ratings and service factors Fm and Fs

Mechanical ratings measure capacity in terms of life and/or strength, assuming 10 hr/day continuous running under uniform load conditions.

Catalog ratings allow 100% overload at starting, braking or momentarily during operation up to 10 times per day.

The unit selected must therefore have a catalog rating at least equal to half maximum overload.

Mechanical Service Factor Fm (Table 1) is used to modify the actual load according to daily operating time, and type of loading. Required mechanical power rating P(mech) = absorbed power x Fm

Load characteristics for a wide range of applications are detailed in Table 3 opposite, which are used in deciding the appropriate Service Factor Fm from Table 1.

If loading can be calculated, or accurately assessed, actual loads should be used instead modifying using Fm.

For units subject to torque reversal or frequent stop/start overloads in excess of 10 times per day, the following check should be made

$$\text{gear unit input power capacity (Hp)} \geq \frac{T_m \times F_s \times n}{2 \times 63000}$$

- Where Tm = motor starting torque (In-lb) or rating of torque limiting device, fluid coupling etc.  
n = input speed (rev/min)  
Fs = number of starts factor (See table 2)

For applications where high inertia loads are involved e.g. crane travel drives, slewing motion etc., or when units are to operate in extremely dusty or moist/humid atmospheres, unit selection should be referred to our Application Engineers.

**Table 1. Mechanical Service Factor (Fm)**

Prime Mover	Duration of service hours per day	Load classification-driven machine		
		Uniform	Moderate Shock	Heavy Shock
Electric motor, stream turbine or hydraulic motor	Under 3	1.00	1.00	1.50
	3 to 10	1.00	1.25	1.75
	Over 10	1.25	1.50	2.00
Multi-cylinder internal combustion engine	Under 3	1.00	1.25	1.75
	3 to 10	1.25	1.50	2.00
	Over 10	1.50	1.75	2.25
Single cylinder internal combustion engine	Under 3	1.25	1.50	2.00
	3 to 10	1.50	1.75	2.25
	Over 10	1.75	2.00	2.50

**Table 2. Number of Starts Factor (Fs)**

Start / Stops per hour (1)	Up to 1	5	10	40	60	≥200
Unidirectional	1.0	1.03	1.06	1.10	1.15	1.20
Reversing	1.4	1.45	1.50	1.55	1.60	1.70

Note: (1) Intermediate values are obtained by linear interpolation

## EXPLANATION AND USE OF RATINGS AND ASSOCIATED RATING FACTORS

### Thermal ratings and service factors

The Thermal ratings are a measure of the gear units ability to dissipate heat. If they are exceeded the lubricant may overheat and breakdown, resulting in gear failure.

Thermal ratings are given on page 39 for parallel shaft units and page 53 for right angle shaft units. The following choices are available:

- i) No additional cooling
- ii) Unit fitted with fan cooling
- iii) Unit fitted with water cooling coil
- iv) Unit fitted with cooling coil and fan

Catalog thermal limitations are based on the unit operating continuously in an environment with an ambient temperature equal to 77°F and in a horizontal mounting position. The thermal rating is affected by ambient temperature, duration of running per hour, altitude and operating area. To account for these varying conditions, the service factors given in tables 4, 5, 6 and 7 should be applied as follows:-

$$P_{\text{therm}} = \frac{\text{Absorbed Power}}{F_t \times F_d \times F_h \times F_v}$$

- $P_{\text{therm}}$  = Required thermal rating (Hp)
- $F_t$  = Service factor for ambient temperature (see Table 4)
- $F_d$  = Service factor for intermittent duty (see Table 5)
- $F_h$  = Thermal service factor for altitude (see Table 6)
- $F_v$  = Thermal service factor for air velocity correction (operating area) (see Table 7)

**Table 4. Ambient Temperature Adjustment Factor (Ft)**

Unit Type	Ambient Temperature °F (°C)							
	-4°F (-20°C)	14°F (-10°C)	32°F (0°C)	60°F (15°C)	77°F (25°C)	86°F (30°C)	95°F (35°C)	112°F (45°C)
All Units	1.65	1.50	1.35	1.14	1.00	0.93	0.86	0.71

**Table 5. Intermittent Duty Factor (Fd)**

Unit Output Speed (rev/min)	% Running time per hour				
	100	80	60	40	20
0 to 10	1.00	1.18	1.45	1.72	2.38
>10 to 25	1.00	1.16	1.39	1.64	2.22
>25 to 50	1.00	1.14	1.31	1.54	2.00
>50 to 100	1.00	1.08	1.19	1.33	1.64
>100 to 150	1.00	1.04	1.08	1.19	1.41
>150 to 200	1.00	1.00	1.00	1.06	1.23
>200	1.00	1.00	1.00	1.00	1.00

**Table 6. Altitude Adjustment Factor (Fh)**

Altitude (m) (ft)	Factor Fh
Sea Level	1.0
500 (1640')	0.97
1000 (3280')	0.93
1500 (4921')	0.90
2000 (6562')	0.87
3000 (9843')	0.81
4000 (13123')	0.75
5000 (16404')	0.70

**Table 7. Ambient Air Velocity Correction Factor (Fv)**

Use FV = 1.0 For Units with Fan Cooling

Operating Area	If Vv is not known use this value for Fv	Air Velocity Vv m/sec (mph)	Factor Fv If Vv is known use this formula for Fv
Small confined space (no Fan)	0.86	0 - 1.4 (0 - 3 mph)	$F_v = 0.1 V_v + 0.86$
Large indoor space (& fan cooled)	1.0	> 1.4 - < 6 (3 - 14 mph)	$F_v = 0.2 V_v + 0.72$
Sheltered outdoor space (no fan)	1.3	> 2 - < 6 (5 - 14 mph)	$F_v = 0.17 V_v + 0.9$
Outdoor space (no fan)	1.5	> 2 (5mph)	$F_v = 0.17 V_v + 0.9$ (max Fv = 1.92)

### General

When checking thermal capacities of units, use actual load required to be transmitted, not rating of prime mover.

# SERIES G

## EXPLANATION AND USE OF RATINGS AND ASSOCIATED RATING FACTORS

**Table 3**

**U = Uniform load**

**M = Moderate shock load**

**H = Heavy shock load**

**† = Refer to Application Engineering**

Driven Machine	type of load	Driven Machine	type of load	Driven Machine	type of load
<b>Cranes</b>		log haul-incline	H	log haul presses	H
main hoists	†	log haul-well type	H	pulp machine reel	M
bridge travel	†	log turning device	H	stock chest	M
trolley travel	†	main log conveyor	H	suction roll	M
		off bearing rolls	M	washers and thickeners	M
<b>Crusher</b>		planer feed chains	M	winders	M
ore	H	planer floor chains	M		
stone	H	planer tilting hoist	M	<b>Printing presses</b>	†
sugar	H	re-saw merry-go-round conveyor	M	<b>Pullers</b>	
		roll cases	H	barge haul	H
<b>Dredges</b>		slab conveyor	H	<b>Pumps</b>	
cable reels	M	small waste conveyor-belt	U	centrifugal	U
conveyors	M	small waste conveyor-chain	M	proportioning	M
cutter head drives	H	sorting table	M	reciprocating	
jig drives	H	tipple hoist conveyor	M	single acting; 3 or more cylinders	M
maneuvering winches	M	tipple hoist drive	M	double acting; 2 or more cylinders	M
pumps	M	transfer conveyors	M	single acting; 1 or 2 cylinders	†
screen drive	H	transfer rolls	M	double acting; single cylinder	†
stackers	M	tray drive	M	rotary	
utility winches	M	trimmer feed	M	gear type lobe, vane	U
		waste conveyor	M		
<b>Dry dock cranes</b>		<b>Machine tools</b>		<b>Rubber and plastics industries</b>	
main hoist	†	bending roll	M	crackers	H
auxiliary hoist	†	punch press-gear driven	H	laboratory equipment	M
boom, luffing	†	notching press- belt driven	†	mixed mills	H
rotating, swing or slew tracking, drive wheels	†	plate planers	H	refiners	M
		tapping machine	H	rubber calenders	M
<b>Elevators</b>		other machine tools		rubber mill-2 on line	M
bucket-uniform load	U	main drives	M	rubber mill-3 on line	M
bucket-heavy load	M	auxiliary drives	U	sheeter	M
bucket-continuous	U			tire building machines	†
centrifugal discharge	U	<b>Metal mills</b>		tire and tube press	†
escalators	U	draw bench carriage and main drive	M	openers	†
freight	U	pinch, dryer and scrubber rolls-reversing	†	tubers and strainers	M
gravity discharge	M	slitters	M	warming mills	M
man lifts	†	table conveyors			
passenger	†	non-reversing		<b>Sand muller</b>	M
		group drives	M	<b>Sewage disposal equipment</b>	
<b>Fans</b>		individual drives	H	bar screens	U
centrifugal	U	reversing		chemical feeders	U
cooling towers		wire drawing and flattening machine	M	collectors	U
induced draft	†	wire winding machine	M	dewatering screws	M
forced draft	†			scum breakers	M
induced draft	M	<b>Mill-rotary type ball</b>		slow or rapid mixers	M
large, mine, etc	M	cement kilns	H	thickeners	M
large, industrial	M	dryers and coolers	H	vacuum filters	M
light, small diameter	U	kilns, other than cement pebble rod	H		
		plain	H	<b>Screens</b>	
<b>Feeders</b>		wedge bar	H	air washing	U
apron	M	tumbling barrels	H	rotary-stone or gravel travelling water intake	U
belt	M			<b>Slab pushers</b>	M
disc	U	<b>Mixers</b>		<b>Steering gear</b>	†
reciprocating	H	concrete mixers		<b>Stokers</b>	U
screw	M	-continuous	M	<b>Sugar industry</b>	
		concrete mixers	M	cane knives	M
<b>Food industry</b>		-intermittent	M	crushers	M
beef slicer	M	constant density	U	mills	M
cereal cooker	U	variable density	M		
dough mixer	M	<b>Oil industry</b>		<b>Textile industry</b>	
meat grinders	M	chillers	M	batchers	M
		oil well pumping	†	calenders	M
<b>Generators-not welding</b>	U	paraffin filter press	M	cards	M
<b>Hammer mills</b>	H	rotary kilns	M	dry cans	M
<b>Hoists</b>		<b>Paper mills</b>		dryers	M
heavy duty	H	agitators, (mixers)	M	dyeing machinery	M
medium duty	M	barker-auxiliaries-hydraulic	M	knitting machines	†
skip hoist	M	barker-mechanical	M	looms	M
		barking drum	H	mangles	M
<b>Laundry washers</b>		beater and pulper	M	nappers	M
reversing	M	bleacher	U	pads	†
<b>Laundry tumblers</b>	M	calenders	M	range drives	M
<b>Line shafts</b>		calenders-super	H	slashers	M
driving processing equipment	M	converting machine, except cutters, platers	M	soapers	M
light	U	conveyors	U	spinners	M
other line shafts	U	couch	M	tenter frames	M
		cutters-plates	H	washers	M
<b>Lumber industry</b>		cylinders	M	winders	M
barkers-hydraulic-mechanical	M	dryers	M		
burner conveyor	M	felt stretcher	M	<b>Windlass</b>	†
chain saw and drag saw	H	felt whipper	H		
chain transfer	H	jordans	M		
craneway transfer	H				
de-barking drum	H				
edger feed	M				
gang feed	M				
green chain	M				
live rolls	H				
log deck	H				

## SELECTION PROCEDURE

### EXAMPLE APPLICATION DETAILS

Absorbed power of driven machine = 120 HP  
 Output speed of gearbox or Input speed of machine = 81 rev/min  
 Application = Uniformly loaded belt conveyor operating in a large indoor space  
 Duration of service (hours per day) = 24hrs  
 Motor speed = 3 phase electric motor, 4 pole, 1750 rev/min  
 Mounting position = Horizontal, Right Angle Shaft  
 Ambient temperature = 86°F (30°C)  
 Running time (%) = 100%  
 Altitude = Sea Level

### 1 DETERMINE RATIO OF GEARBOX REQUIRED

$$\frac{\text{Motor speed}}{\text{Gearbox output speed}} = \frac{1750}{81} = 21.605$$

Refer to exact ratios (page 48) for nearest nominal ratio = 22

### 3 DETERMINE REQUIRED MECHANICAL OUTPUT TORQUE CAPACITY OF GEARBOX

Required mechanical = Absorbed power x Fm rating (Pmech)

$$P_{mech} = 120 \times 1.25 = 150 \text{ HP}$$

### 2 DETERMINE MECHANICAL SERVICE FACTOR (Fm)

Refer to Load Classification by Application, table 3, page 7

Application = Uniformly loaded belt conveyor

#### Conveyors-uniformly loaded or fed

apron	U	U = Uniform load
assembly	U	
belt	U	
bucket	U	
chain	U	

Refer to mechanical service factor (Fm), table 1, page 5

Duration of service (hours per day) = 24hrs

Prime mover	Duration of service-hrs per day	Load classification-drive	
		Uniform	Moderate Shock
Electric motor, steam turbine or hydraulic motor	Under 3	1.00	1.00
	3 to 10	1.00	1.25
	Over 10	1.25	1.50

Therefore mechanical service factor (Fm) = 1.25

### 4 DETERMINE SIZE OF GEAR BOX REQUIRED

Unit input power capacity  $\geq$  Pmech

Refer to ratings tables, Input speed = 1750rev/min, therefore refer to page 49.

NOMINAL RATIO	NOMINAL OUTPUT SPEED REV / MIN	CAPACITY	RIGHT ANGLE UNIT - SIZE			
			G14	G15	G16	G17
22.	79.5	Input Power - HP	112	166	282	393
		Output Torque - lb-in	85000	124000	213000	313000

Mechanical input power capacity must be equal or more than required mechanical input power capacity of the gear box (Pmech). Required mechanical input power = 150 HP. At a 22:1 ratio, nominal output speed 79.5 a G15 unit has a mechanical input power capacity of 166 HP. Therefore the unit is acceptable.

If the unit is subject to torque reversal or frequent stop /starts the input power capacity must be checked in accordance with the formulae on page 5.

### 5 DETERMINE EXACT RATIO OF GEARBOX

Refer to exact ratios table, page 48

Nominal Ratio Column Entry	14	15	16	17
6 7 8				
2 2 .	21.775	21.541	21.756	22.894

Exact ratio = 21.541

Go to point 6 page 9

# SERIES G

## SELECTION PROCEDURE

### 6 DETERMINE THERMAL SERVICE FACTOR (Ft)

Refer to table 4, page 6  
Ambient temperature = 86°F (30°C)

Ambient temperature °C	-4 (-20°C)	-14 (10°C)	32 (0°C)	60 (15°C)	77 (25°C)	86 (30°C)
Factor Ft	1.57	1.43	1.29	1.14	1.00	0.93

Ft = 0.93

### 7 DETERMINE THERMAL SERVICE FACTOR (Fd)

Refer to table 5, page 6  
Unit running time per hour = 100%  
Nominal output speed (rev/min) = 80

Unit Output Speed (rev/min)	% Running time per hour	
	100	80
>10 to 25	1.0	1.16
>25 to 50	1.0	1.14
>50 to 100	1.0	1.08

Fd = 1.0

### 8 DETERMINE ALTITUDE ADJUSTMENT THERMAL SERVICE FACTOR (Fh)

Refer to table 6, page 6

Altitude (m)	Factor Fh
Sea Level	1.0
500	0.97
1000	0.93

Fh = 1.0

### 9 DETERMINE AMBIENT AIR VELOCITY FACTOR (Fv)

Use Fv = 1.0 For Units with Fan Cooling

Operating Area	If Vv is not known use this value for Fv	Air Velocity Vv m/sec	Factor Fv If Vv is known use this formula for Fv
Small confined space	0.86	0 - 1.4	$Fv = 0.1 Vv + 0.86$
Large indoor space	1.0	> 1.4 - < 6	$Fv = 0.2 Vv + 0.72$

Fv = 1.0

### 10 CALCULATE REQUIRED THERMAL RATING Ptherm

$$P_{therm} = \frac{\text{Absorbed Power (Hp)}}{F_t \times F_d \times F_h \times F_v}$$

$$P_{therm} = \frac{120}{0.93 \times 1.0 \times 1.0 \times 1.0}$$

$$P_{therm} = 129 \text{ HP}$$

### 11 CHECK THERMAL CAPACITY

See Page 53

Thermal Rating  $\geq$  Ptherm

#### Thermal Ratings HP

#### Right Angle Shaft Units - Triple Reduction

Type of Cooling	Input Speed (rev/min)	Ratio	G1430	G1530	G1630
No Additional Cooling	875	12:1	82	86	141
		25:1	64	71	120
		56:1	41	49	86
Fan Cooling	1750	12:1	240	243	386
		25:1	206	216	350
		56:1	149	167	282
	1450	12:1	212	215	347
		25:1	181	190	314
		56:1	129	145	250
	1160	12:1	185	188	308
		25:1	157	165	277
		56:1	111	125	219
	875	12:1	163	167	277
		25:1	137	146	248
		56:1	96	109	194
Cooling Coil	1750	12:1	233	242	377
		25:1	199	215	342
		56:1	142	165	275

Ptherm = 129 HP  
therefore unit requires cooling.

Thermal rating for the nearest fan cooled G15 unit is

25:1 ratio = 216 HP.

Thermal capacity is therefore acceptable.

### 12 CHECK OVERHUNG LOADS

If sprocket, gear, etc is mounted on the input or output shaft then refer to Overhung loads procedure, pages 27 - 30

### 13 CHECK COUPLING HUB CAPACITIES

**NOTE:** It is advisable that all selections are verified by our Application Engineers.

If any of the following conditions occur then our Application Engineers must be consulted:-

- a) Inertia of the Driven Machine (Referred to motor speed) >1.0
  - b) Ambient temperature is above 122°F (50°C)
- Inertia of Gear Unit plus Motor

# SERIES G

## UNIT HANDINGS & SHAFT ROTATIONS

### PARALLEL SHAFT UNITS

#### Column 14 Entry - Output Shaft Positions

L		R		D	
SINGLE EXTENSION ON LEFT		SINGLE EXTENSION ON RIGHT		DOUBLE EXTENSION	
Horizontal	Vertical	Horizontal	Vertical	Horizontal (Not applicable on vertical units)	

Note: for shaft mounted units driven machine side (opposite to shrink disk) is assumed as extension side.

#### Column 15 Entry - Input Shaft Positions

L		R		D	
SINGLE EXTENSION ON LEFT		SINGLE EXTENSION ON RIGHT		DOUBLE EXTENSION	
Horizontal	Vertical	Horizontal (Not applicable on vertical units)		Horizontal (Not applicable on vertical units)	

#### Column 16 Entry - Shaft Rotations

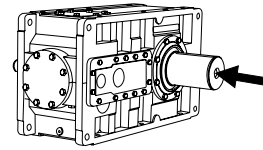

Rotation directions are defined as viewed from output shaft end\*\* (This side if double extended or keyed hollow sleeve)

\*\* Driven machine side for shaft mounted units, opposite side to shrink disk.

Rotation		Parallel Shaft	
Outputshaft	Inputshaft	2 Stage & 4 Stage	3 Stage
Clockwise	Clockwise	<b>1 (std)</b>	n/a
Anticlockwise	Anticlockwise	2	n/a
Clockwise	Anticlockwise	n/a	<b>1 (std)</b>
Anticlockwise	Clockwise	n/a	2

All units are rotation reversible, except when fitted with a backstop (anti-runback device).

(std) if no rotation is entered rotation will be assumed as standard build.



<b>Double &amp; Quadruple Reduction</b>	<b>Horizontal Mounting</b>	<div style="display: flex; justify-content: space-around;"> <div style="text-align: center;"><b>L R 1</b> </div> <div style="text-align: center;"><b>R R 1</b> </div> <div style="text-align: center;"><b>D R 1</b> </div> <div style="text-align: center;"><b>R L 1</b> </div> <div style="text-align: center;"><b>L L 1</b> </div> </div> <div style="display: flex; justify-content: space-around; margin-top: 10px;"> <div style="text-align: center;"><b>D L 1</b> </div> <div style="text-align: center;"><b>L D 1</b> </div> <div style="text-align: center;"><b>R D 1</b> </div> <div style="text-align: center;"><b>D D 1</b> </div> </div>
	<b>Vertical Mounting</b>	<div style="display: flex; justify-content: space-around;"> <div style="text-align: center;"><b>R L 1</b> </div> <div style="text-align: center;"><b>L L 1</b> </div> </div>
<b>Triple Reduction</b>	<b>Horizontal Mounting</b>	<div style="display: flex; justify-content: space-around;"> <div style="text-align: center;"><b>L R 1</b> </div> <div style="text-align: center;"><b>R R 1</b> </div> <div style="text-align: center;"><b>D R 1</b> </div> <div style="text-align: center;"><b>R L 1</b> </div> <div style="text-align: center;"><b>L L 1</b> </div> </div> <div style="display: flex; justify-content: space-around; margin-top: 10px;"> <div style="text-align: center;"><b>D L 1</b> </div> <div style="text-align: center;"><b>L D 1</b> </div> <div style="text-align: center;"><b>R D 1</b> </div> <div style="text-align: center;"><b>D D 1</b> </div> </div>
	<b>Vertical Mounting</b>	<div style="display: flex; justify-content: space-around;"> <div style="text-align: center;"><b>R L 1</b> </div> <div style="text-align: center;"><b>L L 1</b> </div> </div>

Note: parallel shaft unit handings **R R** or **L L** are subject to a reduction in external overhung load capacities

# SERIES G

## UNIT HANDINGS & SHAFT ROTATIONS RIGHT ANGLE SHAFT UNITS

### Column 14 Entry - Output Shaft Positions

L SINGLE EXTENSION ON LEFT		R SINGLE EXTENSION ON RIGHT		D DOUBLE EXTENSION	
Horizontal	Vertical	Horizontal	Vertical	Horizontal (Not applicable on vertical units)	

Note: for shaft mounted units driven machine side (opposite to shrink disk) is assumed as extension side.

### Column 16 Entry - Shaft Rotations

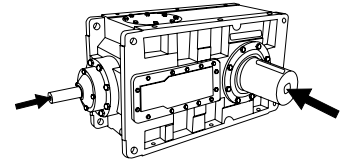

Rotation directions are defined as viewed from output shaft end\*\* (This side if double extended or keyed hollow sleeve)

\*\* Driven machine side for shaft mounted units, opposite side to shrink disk.

### Column 15 Entry - Input Shaft Positions

B STANDARD RIGHT ANGLE EXTENSION		J RIGHT ANGLE UNIT TYPE J	
Horizontal	Vertical	Horizontal	Vertical

Note: Only available as standard for ratios:  
G14, G16, G18 - 22:1 to 63:1  
G15, G17, G19 - 28:1 to 80:1

Rotation		Right Angle Shafts
Outputshaft	Inputshaft	3 Stage & 4 Stage
Clockwise	Clockwise	1 (std)
Anticlockwise	Anticlockwise	2
Clockwise	Anticlockwise	3 *
Anticlockwise	Clockwise	4 *

All units are rotation reversible, except when fitted with a backstop (anti-runback device).

(std) if no rotation is entered rotation will be assumed as standard build.

Right Angle Shafts - Triple & Quadruple Reduction	Horizontal Mounting			
	Vertical Mounting			
Type J Shafts - Triple & Quadruple Reduction	Horizontal Mounting			
	Vertical Mounting			

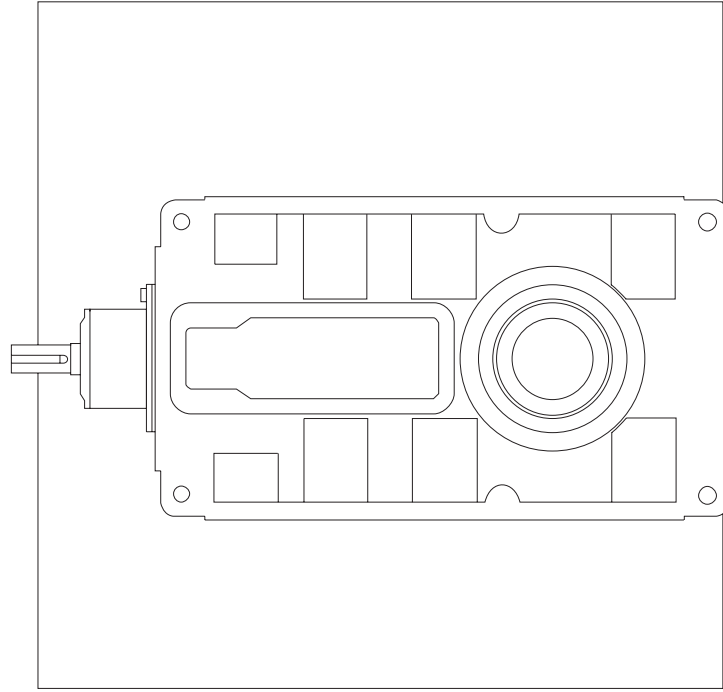

**INSTALLATION,  
MAINTENANCE,  
LUBRICATION**

# **SERIES G**

### General

The following instructions will help you achieve a satisfactory installation of your Series G unit, ensuring the best possible conditions for a long and trouble free operation.

**WARNING:** The customer shall be responsible for the proper use of articles supplied by the company, particularly the rotating shafts between their driving and driven members, and their guarding for safety, and the company shall not be responsible for any injury or damage sustained as a result of the improper use of the articles supplied.



Attention is hereby drawn to the danger of using exposed lights in proximity to openings in gearboxes and gear units supplied by the company, and the company shall not be liable for any claim for injury or damage arising from any action in contravention of this warning.

**WARNING:** All units and couplings are shipped without oil or grease, on installing the unit fill with recommended lubricant to correct level.

### 1.0 FITTING OF COMPONENTS TO EITHER THE UNIT INPUT OR OUTPUT SHAFT

The input or output shaft extension diameter tolerance is + 0 to - 0.0005 inches for shafts up to 1.5 inches diameter and +0 to -0.001 for shafts larger than 1.5 inches diameter. The fitted component should be machined to ensure a proper fit.

- Items (such as gears, sprockets, couplings etc) should not be hammered onto these shafts since this would damage the shaft support bearings.
- The item should be pushed onto the shaft using a screw jack device fitted into the threaded hole provided in the end of the shaft.
- Items being fitted maybe heated to 176/212°F (80/100°C) to aid assembly further.

#### THREADED HOLE DETAILS

UNIT SIZE	TYPE OF UNIT	INPUT SHAFT	OUTPUT SHAFT
14 & 15	Parallel 2 Stage	5/8" UNF x 1.25 deep	1" UNF x 2 deep
	Parallel 3 & 4 Stage	1/2" UNF x 1 deep	
	Right Angle 3 Stage	5/8" UNF x 1.25 deep	
16 & 17	Parallel 2 Stage	3/4" UNF x 1.62 deep	1.25" UNF x 2.5 deep
	Parallel 3 & 4 Stage	5/8" UNF x 1.25 deep	
	Right Angle 3 Stage	5/8" UNF x 1.25 deep	
	Right Angle 4 Stage	5/8" UNF x 1.25 deep	
18 & 19	Parallel 2 Stage	1" UNF x 2 deep	1.5" UNF x 3 deep
	Parallel 3 & 4 Stage	3/4" UNF x 1.62 deep	
	Right Angle 3 Stage	3/4" UNF x 1.62 deep	
	Right Angle 4 Stage	5/8" UNF x 1.25 deep	
21 & 22	Parallel 2 Stage	1" UNF x 2 deep	1.5" UNF x 3 deep
	Parallel 3 & 4 Stage	3/4" UNF x 1.62 deep	
	Right Angle 3 Stage	1" UNF x 2 deep	
	Right Angle 4 Stage	3/4" UNF x 1.62 deep	

### 2.0 WEATHER PROTECTION OF UNIT

All Series G units are provided with protection against normal weather conditions. Where units are to operate in extreme conditions, or where they are to stand for long periods without running, e.g. during plant construction, we should be notified when ordering so that arrangements for adequate protection can be made.

## INSTALLATION & MAINTENANCE

### 3.0 INSTALLATION

All units are shipped less oil, for the customer to fill on site once installed. Care should be taken to ensure the correct type and quantity of lubricant for the chosen mounting position is used. Ensure that the breather/filling plug, dipstick and drain plugs are installed in the correct position

- Page 19 gives approximate lubricant quantities for each mounting position
- Pages 19 and 20 show a list of lubricants approved for use in the gear unit.
- See appropriate dimension page for positions of breather/filling plug, dipstick and drain plugs

### 3.1 LIFTING

Only the lifting points identified on the gearbox or bedplate must be used for lifting operations during installation.

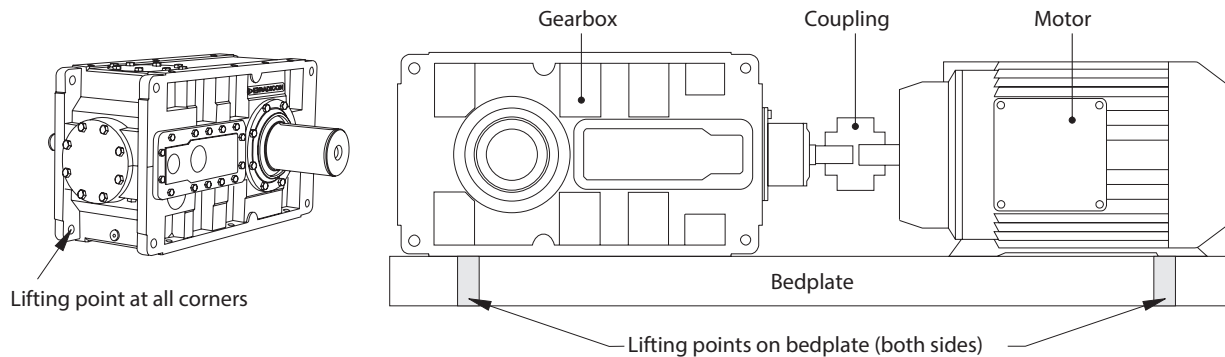

#### Gearbox Only

The gearbox can be lifted using any of the eight lifting points.

Note:

#### Gearbox on Bedplate

The lifting points on the bedplate must be used to lift the whole drive assembly. Do NOT use the lifting points on the gearbox to lift the bedplate assembly.

Failure to use these lifting points could result in personal injury/or damage to the product and surrounding equipment

### 3.2 GENERAL

Drives must be installed on rigid, flat and vibration free beds. Align the driving and driven units carefully to avoid any increased loads on the shafts and bearings due to misalignment.

The unit should be fixed by means of bolts to ISO grade 8.8 minimum or equivalent and torque tightened to:

Screw Size	Tightening Torque
1/2" (M12)	750 lb-ins ( 85 Nm )
5/8" (M16)	1770 lb-ins ( 200 Nm )
3/4" (M20)	3100 lb-ins ( 350 Nm )
1" (M20)	5400 lb-ins ( 610 Nm )
1 1/4" (M30)	10,800 lb-ins ( 1220 Nm )
1 1/2" (M36)	19,030 lb-ins ( 2150 Nm )
1 3/4" (M42)	30,600 lb-ins ( 3460 Nm )

### 3.3 GUARDS

The customer must ensure that any exposed rotating shafts and couplings, guards must be fitted in accordance with the relevant state and local safety regulations.

### 3.4 CONNECTING ELECTRIC MOTOR

Connection of the electric motor to the mains supply should be made by a qualified person. The current rating of the motor will be identified on the motor plate, and correct sizing of the cables to electrical regulations is essential.

### 3.5 FOOT-MOUNTED UNITS

The following procedure is recommended for all foot mounted units. Foot mounted units are supplied either as free standing units, or if required, mounted on a standard baseplate with a foot mounted motor correctly aligned and connected by a flexible coupling.

- a) Clean shaft extensions and breather when fitted.
- b) Secure unit, or baseplate if fitted to a rigid foundation using heavy duty bolts to ISO grade 8.8 minimum or equivalent.
- c) Ensure baseplate is not distorted Note: Units not supplied on baseplates should if possible be mounted on the same bedplate as the prime mover.
- d) Align unit

Note: It is important to ensure when aligning unit on baseplate that all machined mounting points are supported over their full area. If steel shims are used these should be placed either side of the foundation bolt as close as possible. During the final bolting ensure the unit or baseplate is not distorted this will cause strains in the gear case resulting in errors of alignment of shafts and gearing.

- e) For units mounted on bedplates after alignment select any two diagonally opposite feet, drill ream and dowel in position.
- f) Fit guards in accordance with current local, state and federal regulations.
- g) Check motor wiring for correct direction of rotation this is important when a backstop device is fitted.
- h) Fill gear unit with oil as detailed on page 18 - 20.

### 3.6 SHAFT MOUNTED UNITS

The following procedure is recommended for all shaft and foot/shaft mounted units.

- a) Clean shaft extensions, driven machine shaft, gear unit bore and breather when fitted.
- b) Locate in position, ensuring it is as close as possible to the bearing on the driven machine.
- c) Secure unit onto the shaft. For units using a shrink disk device refer to section 3.6.1
- d) Fit torque arm to the side of the unit adjacent to the driven machine where possible, as detailed below. Note: Unless specified otherwise, the torque arm will be supplied loose.
- e) Anchor case to a secure point by means of the torque arm.
- f) Fit guards in accordance with current local, state and federal regulations.
- g) Check motor wiring for correct direction of rotation, this is important when a backstop device is fitted.
- h) Fill gear unit with oil as detailed on page 18 - 20.

Figure 1

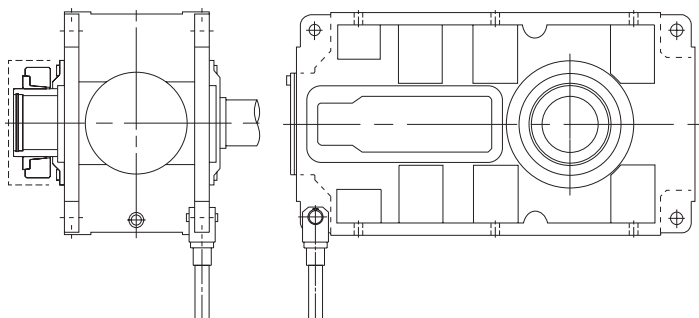
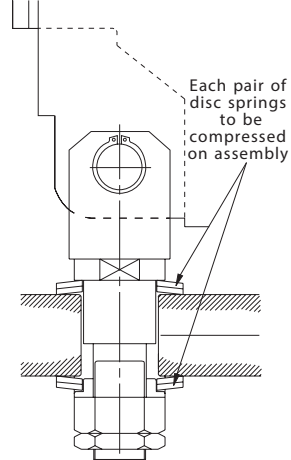

Figure 2

The torque arm must be flexibly mounted to the chassis structure



## INSTALLATION & MAINTENANCE

### 3.6.1 SHAFT MOUNTED UNITS USING A SHRINK DISK DEVICE

The gear unit is fitted with a 'shrink disk' device located on the hollow output shaft to provide a positive outer locking connection between gear unit and driven shaft. The 'shrink disk' is a friction device without keys, which exerts an external clamping force on the hollow output shaft, thus establishing a mechanical shrink fit between the gear unit hollow shaft and driven shaft. 'Shrink Disk' capacities have ample margins in dealing with transmitted torques and external loading imposed on gear units.

The 'shrink disk' consists of a locking collar, a tapered inner ring and locking screws. By tightening the locking screws, the locking collar and tapered inner ring are pulled together, exerting radial forces on the inner ring, thus creating a positive friction connection between hollow shaft and driven shaft (see figure 2).

As the tapered surfaces of locking collar and inner ring are lubricated with Molykote 321R or similar and the taper angle is not self locking, locking collar will not seize on the inner ring and can be released easily when removal is necessary.

When the 'shrink disk' is clamped in position the high contact pressures between tapered surfaces and screw heads and their seatings ensure hermetic sealing and eliminate the possibility of fretting corrosion.

### INSTALLATION

'Shrink disks' are supplied with shaft mounted units. The following procedures should be followed when fitting or removing units from the driven shaft.

- 1 Release locking screws gradually and in succession. Initially a quarter of a turn on each screw will avoid tilting and jamming - do not remove locking bolts completely.
- 2 Remove 'shrink disk' - from gear unit hollow shaft.
- 3 Clean and degrease locating diameters of gear unit hollow shaft, driven shaft and 'shrink disk' locating diameter on hollow shaft extension.
- 4 Draw the gear unit onto the driven shaft (see figure 3)
- 5 Grease tapered surfaces of outer ring and inner ring with Molykote 321R or similar.
- 6 Fit 'shrink disk' on gear unit hollow shaft to position shown in figure 1 page 61.
- 7 Tighten all locking screws gradually and in succession. Do not tighten in a diametrically opposite sequence. Several passes are required until all screws are tightened until the inner and outer ring faces are in-line and the torque figures  $T_a$  shown in the table on page 61 are achieved.
- 8 Fit protective cover

Note: When the hollow output shaft is to operate in a vertical position it is essential that the shaft of the driven machine is provided with a shoulder. When the thrust load is not taken by the shoulder on the driven shaft, a thrust plate, as shown on page 61, must be fitted.

It is recommended that customers' shafts at the non-clamped end of the sleeve should be coated with Molykote 321R or equivalent.

### REMOVAL

- 1 Removal procedure is similar to the reverse of installation.
- 2 Remove any rust and dirt from gear unit hollow shaft.
- 3 Withdraw gear unit from driven shaft (see figure 4)

Note: 'Shrink disk' should be removed and cleaned thoroughly, and Molykote 321R or similar applied to the tapered surfaces of inner ring and locking collar before re-use.

Note: Protective covers are supplied with all 'shrink disks'. Assembly or removal kits and thrust plates are not provided.

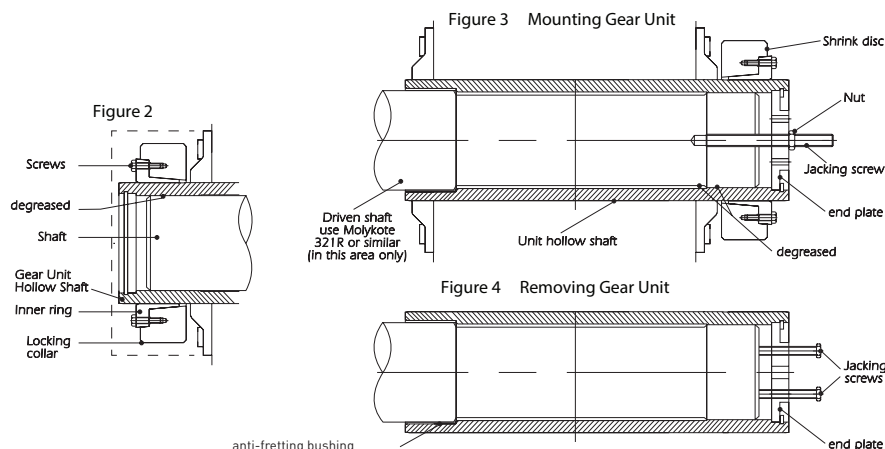

### **3.7 OIL / GREASE CHANGES**

On all sizes regular oil changes are essential and the following factors should be used to determine the frequency at which these are carried out.

- a. Oil temperature - unit operating under load.
- b. Type of oil.
- c. Environment - humidity, dust, etc.
- d. Operating conditions - shock, loading, etc.

At elevated temperatures the effective life of the oil is very much reduced. This is most pronounced with oils containing fatty and E.P. additives. To prevent damage to the unit through lubricant breakdown the oil should be renewed as detailed in the following table:

UNIT OPERATING TEMPERATURE °F	RENEWAL PERIOD	
	MINERAL OIL	SYNTHETIC OIL
167 (75°C) OR LESS	17000 HOURS or 3 YEARS	26000 HOURS or 3 YEARS
176 (80°C)	12000 HOURS or 3 YEARS	26000 HOURS or 3 YEARS
185 (85°C)	8500 HOURS or 3 YEARS	21000 HOURS or 3 YEARS
194 (90°C)	6000 HOURS or 2 YEARS	15000 HOURS or 3 YEARS
203 (95°C)	4200 HOURS or 17 MONTHS	10500 HOURS or 3 YEARS
212 (100°C)	3000 HOURS or 12 MONTHS	7500 HOURS or 2.5 YEARS
NB: INITIAL FILL OF OIL SHOULD BE CHANGED IN A NEW GEAR UNIT AFTER 1000 HOURS OPERATION OR ONE YEAR OR HALF THE ABOVE LIFE WHICHEVER IS THE SOONEST		

### **3.7 OIL / GREASE CHANGES**

On all sizes regular oil changes are essential and the following factors should be used to determine the frequency at which these are carried out.

Note:

Figures quoted are for oil temperatures when the unit has attained normal running temperature when operating under load. These figures are based on normal running but where conditions are particularly severe it may be necessary to change the oil more frequently. When changing lubricant, if same lubricant is not used then unit must be flushed out and filled only with one type of lubricant.

The procedure for changing an oil should be to drain the oil preferably when hot and after circulation. If the gear unit is to be flushed, the unit should be filled to the appropriate level with an oil of the same viscosity grade and type as the lubricating oil and run before the flushing oil is drained. This procedure should be followed especially if the type of oil is being changed. The unit should be filled with the approved oil to the level marked on the dipstick. Re-check the oil level after a short period of running and top up as necessary. On certain units the output shaft bearings are grease lubricated, these should be re-greased at 2000 to 3000 hour intervals unless otherwise instructed.

### **3.8 ROUTINE MAINTENANCE**

Periodically check that the fixing bolts are properly tightened and that everything is correctly aligned.

Once a week the oil level should be checked and lubricant added if required. Carry out oil changes in accordance with the Table above. On certain units the output shaft bearings are grease lubricated, these should be re-greased at 2000 to 3000 hour intervals unless otherwise instructed.

### **3.9 CLEANING**

With the drive stationary periodically clean any dirt or dust from the gear unit and the electric motor cooling fins and fan guard to aid cooling.

### **3.10 GENERAL SAFETY**

Potential hazards which can be encountered during installation, maintenance and operation of drives is covered in greater detail in the Series G installation and maintenance booklet.

Any further information or clarification required may be obtained by contacting our Application Engineers.

**TABLE 6 FAULT DIAGNOSIS**

Symptom	Possible Causes	Remedy
Output shaft does not rotate, even though the motor is running or the input shaft is rotating.	Drive between shafts interrupted in the gear unit.	Return the gear unit / geared motor for repair.
Unusual, regular running noise	<ul style="list-style-type: none"> <li>a) A meshing or grinding sound : damage to bearings</li> <li>b) A knocking sound : irregularity in gearing</li> </ul>	<ul style="list-style-type: none"> <li>a) Check oil (See Maintenance)</li> <li>b) Contact our Application Engineers or your local Sales Office</li> </ul>
Unusual, irregular running noise	Foreign matter present in the oil	<ul style="list-style-type: none"> <li>a) Check oil (See Maintenance)</li> <li>b) Stop the unit, contact our Application Engineers or your local Sales Office</li> </ul>
Oil leaking <sup>1</sup> <ul style="list-style-type: none"> <li>• from gear unit cover</li> <li>• from motor flange</li> <li>• from gear unit flange</li> <li>• from output end oil seal</li> </ul>	<ul style="list-style-type: none"> <li>a) Defective gasket on gear unit cover</li> <li>b) Defective gasket</li> <li>c) Gear unit not ventilated</li> </ul>	<ul style="list-style-type: none"> <li>a) Retighten screws on gear unit cover and observe gear unit. If still oil leaks contact our Application Engineers or your local Sales Office.</li> <li>b) Contact our Application Engineers or your local Sales Office.</li> <li>c) Vent the gear unit.</li> </ul>
Oil leaking from the ventilator	<ul style="list-style-type: none"> <li>a) Gear unit over filled with oil</li> <li>b) Gear unit installed in an incorrect mounting position</li> <li>c) Frequent cold starts (oil foaming) and/ or high oil level</li> </ul>	<ul style="list-style-type: none"> <li>a) Correct the oil level (See Lubrication)</li> <li>b) Correct the mounting position and check oil level (See Lubrication)</li> <li>c) Check the oil level (See Lubrication)</li> </ul>

1) It is normal for small amounts of oil / grease to leak out of the oil seal during the running in period (24 hours running time)

When contacting our sales office please have the following information available:

- Nameplate data (complete)
- Type and extent of the problem encountered
- The time and the circumstances the problem occurred
- A possible cause

Any further information or clarification required may be obtained by contacting Our sales office, please see contact details at the back of this booklet.

# SERIES G

## LUBRICATION

All Series G units are shipped without oil (a warning label is attached), and therefore filled by the client. The grade and type of oil will be stamped on the nameplate in accordance with either of the types of oil from tables 2 and 3. Recommended oils are listed in the Approved Lubrication section. The oil change period shall be determined from clause 3.7 on page 17.

The approximate quantity of oil required is given in Table 1, but the unit should always be filled to the level marked on the dipstick or any other level indicator fitted (sight glass etc). Warning: Do not overfill the unit as this can cause leakage and overheating.

Where possible run the unit without load for a short time to circulate the lubricant thoroughly, then stop the unit and re-check the oil level after allowing the unit to stand for 10 minutes and if necessary top up to the correct mark on the dipstick or any other level indicator fitted (sight glass etc).

In addition where bearings are grease packed, the greases approved are NLGI grade 2 and recommended greases are listed in the Approved Lubrication section.

**TABLE 1 LUBRICANT QUANTITY (Gallons)**

Unit Type		UNIT SIZE							
		14	15	16	17	18	19	21	22
Parallel Shaft 2 Stage	Horizontal	5.81	5.28	12.42	11.1	24.3	25.1	47.55	42.53
	Vertical	4.76	4.76	10.57	9.77	21.13	22.45	36.98	39.62
Parallel Shaft 3 Stage	Horizontal	5.55	5.02	12.15	10.83	24.04	24.83	48.87	46.23
	Vertical	4.76	4.76	10.57	9.77	21.13	22.45	36.98	40.95
Parallel Shaft 4 Stage	Horizontal	5.55	5.02	12.15	10.83	24.04	24.83	48.87	46.23
	Vertical	4.76	4.76	10.57	9.77	21.13	22.45	36.98	40.95
Right Angle 3 Stage	Horizontal	5.55	5.02	12.42	11.1	24.3	25.1	48.87	46.23
	Vertical	5.28	5.28	11.36	10.3	22.98	24.3	36.98	44.91
Right Angle 4 Stage	Horizontal	-	-	12.68	11.36	24.83	25.36	50.19	46.23
	Vertical	-	-	11.89	10.3	23.51	23.51	36.98	48.87

**TABLE 2 OIL GRADES**

EP Mineral Oil (type E)

LUBRICANT	AMBIENT TEMPERATURE RANGE		
	23°F to 68°F (-5°C to 20°C)	32°F to 95°F (0°C to 35°C)	60°F to 122°F (20°C to 50°C)
Oil Grade	5E (VG 220)	6E (VG 320)	7E (VG 460)

**TABLE 3 OIL GRADES**

Polyalphaolefin based Synthetic (type H)

LUBRICANT	AMBIENT TEMPERATURE RANGE	
	-22°F to 95°F (-30°C to 35°C)	68°F to 122°F (20°C to 50°C)
Oil Grade	5H (VG 220)	6H (VG 320)

**TABLE 4 APPROVED BEARING GREASES**

SUPPLIER	DESIGNATION	ALLOWABLE OPERATING TEMPERATURE RANGE °F	
		ABOVE	TO
BP Oil International Limited	Energrease LS-EP	-22 (-30°C)	266 (130°C)
Caltex	Multifak EP	32 (0°C)	248 (120°C)
Castrol International	LMX Grease	-40 (-40°C)	302 (150°C)
	Spheerol AP	-22 (-30°C)	230 (110°C)
	Spheerol EPL	50 (10°C)	248 (120°C)
Klüber Lubrication	Klüberlub BE 41-542	-4 (-20°C)	284 (140°C)
Mobil Oil Company Limited	Mobilgrease XHP	-5 (15°C)	302 (150°C)
	Mobilith SHC	-4 (-20°C)	356 (180°C)
Omega Manufacturing Division	Omega 85	-40 (-40°C)	446 (230°C)
Optimol Ölwerke GmbH	Longtime PD	-49 (-45°C)	284 (140°C)
Shell Oils	Albida RL	-4 (-20°C)	302 (150°C)
	Alvania EP B	-4 (-20°C)	248 (120°C)
	Nerita HV	-22 (-30°C)	266 (130°C)
Texaco Limited	Multifak All Purpose EP	-22 (-30°C)	284 (140°C)

Notes:

All the above greases are NLGI grade 2. Contact our application engineers if the unit is operating outside the range - 22°F to 122°F (-30°C - 50°C)

**TABLE 4 APPROVED LUBRICANTS**

**Type E** Mineral oil containing industrial EP additives. These have a high load carrying capacity.

SUPPLIER	LUBRICANT RANGE	See notes page 27	GRADE NUMBERS		
			5E	6E	7E
			23°F to 68°F (-5°C to 20°C)	32°F to 95°F (0°C to 35°C)	68°F to 122°F (20°C to 50°C)
Ampol Limited	Gearlube SP		SP220 (-1)	SP320 (-1)	SP460 (-1)
Batoyle Freedom Group	Remus		220 (-2)	320 (-2)	460 (-2)
Boxer Services Limited	Indus	e	220 (-10)	320 (-10)	460 (-10)
BP Oil International Limited	Energol GR-XF	c,e	220 (-16)	320 (-13)	460 (-1)
	Energol GR-XP	e	220 (-15)	320 (-10)	460 (-7)
Caltex	Meropa		220 (-4)	320 (-4)	460 (-4)
	RPM Borate EP Lubricant		220 (-7)	320 (-4)	460 (-7)
Carl Bechem GmbH	Berugear GS BM		220 (-20)	320 (-13)	460 (-10)
	Staroil G		220 (-13)	320 (-13)	460 (-10)
Castrol International	Alpha Max	c,e	220 (-19)	320 (-13)	460 (-10)
	Alpha SP	e	220 (-16)	320 (-16)	460 (-1)
Chevron International Oil Company Limited	Gear Comp EP (USA ver)		220 (-16)	320 (-13)	460 (-10)
	Gear CompEP (Eastern ver)		220 (-13)	320 (-13)	460 (-13)
	Ultra Gear		220 (-10)	320 (-7)	460 (-7)
Eko-Elda (Greece)	Gearlub		220 (-13)	320 (-10)	460 (-1)
Engen Petroleum Limited	Gengear		220 (-13)	320 (-10)	460 (-1)
Esso	Spartan EP	c	220 (-16)	320 (-13)	460 (-7)
Esso/Exxon	Spartan EP	h	220 (-12)	320 (-12)	460 (-4)
Fina	Giran		220 (-13)	320 (-10)	460 (-10)
Fuchs Lubricants (UK) Plc	Powergear			P/Gear (-16)	M460 (-4)
	Renogear V		220EP (-13)	320EP (-4)	460EP (-4)
	Renogear WE		220 (-7)	320 (-4)	400 (-4)
Fuchs Mineraloelwerke GmbH	Renolin CLPF Super	e	6 (-13)	8 (-10)	10 (-10)
Klüber Lubrication	Klüberoil GEM1		220 (-5)	320 (-5)	460 (-5)
Kuwait Petroleum International	Q8 Goya		220 (-16)	320 (-13)	460 (-10)
Lubrication Engineers Inc	Almasol Vari-Purpose Gear		607 (-18)	605 (-13)	608 (-10)
Mobil Oil Company Limited	Mobil gear 600 Series		630 (-13)	632 (-13)	634 (-1)
	Mobil gear XMP	c	220 (-19)	320 (-13)	460 (-7)
Omega Manufacturing Division	Omega 690	e		85w/140 (-15)	
Optimol Ölwerke GmbH	Optigear BM		220 (-11)	320 (-10)	460 (-7)
	Optigear		220 (-18)	320 (-9)	460 (-7)
Pertamina (Indonesia)	Masri	e	220 (-4)	320 (-4)	460 (-4)
Petro-Canada	Ultima EP	e	220 (-22)	320 (-16)	460 (-10)
Petromin Lubricating Oil Co.	Gear Lube EP	e	EP220 (-1)	EP320 [0]	EP460 [0]
Rocol	Sapphire Hi-Torque	e	220 (-13)	320 (-13)	460 (-13)
Sasol Oil (Pty) Limited	Cobalt	e	220 (-4)	320 (-1)	460 (-4)
	Hemat	e	220 (-10)	320 (-7)	460 (-4)
Shell Oils	Omala		220 (-4)	320 (-4)	460 (-4)
	Omala F	c	220 (-13)	320 (-10)	460 (-4)
Texaco Limited	Meropa	c	220 (-11)	320 (-11)	460 (-5)
	Meropa WM	c	220 (-19)	320 (-16)	460 (-10)
Total	Carter EP		220 (-7)	320 (-7)	460 (-4)
Tribol GmbH	Molub-Alloy Gear Oil		90 (-18)	690 (-16)	140 (-13)
	Tribol 1100		220 (-20)	320 (-18)	460 (-16)

**DANGER**

Numbers in brackets indicate recommended minimum operating temperature in °C

**THE UNIT MUST NOT RUN BELOW THIS TEMPERATURE**

**TABLE 5 APPROVED LUBRICANTS**

**Type H** Polyalphaolefin based synthetic lubricants with Anti-Wear or EP additives. These have a medium to high load carrying capacity.

SUPPLIER	LUBRICANT RANGE	See Notes	GRADE NUMBERS	
			5H	6H
			-22°F to 95°F (-30°C to 35°C)	68°F to 122°F (20°C to 50°C)
Batoyle Freedom Group	Titan		220 (-31)	320 (-28)
Boxer Services Limited	Silkgear		220 (-35)	320 (-35)
BP Oil International Limited	Enersyn EPX	e		320 (-28)
Caltex	Pinnacle EP		220 (-43)	320 (-43)
Carl Bechem GmbH	Berusynth GP		220 (-38)	320 (-35)
Castrol International	Alphasyn EP	c	220 (-37)	320 (-31)
	Alphasyn T		220 (-31)	320 (-28)
Chevron International Oil Co	Tegra		220 (-46)	320 (-33)
Esso/Exxon	Spartan Synthetic EP	e	220 (-46)	320 (-43)
Fina	Giran P		220 (-30)	320 (-25)
Fuchs Lubricants (UK) Plc	Renogear SG		220 (-32)	320 (-30)
Fuchs Mineraloelwerke GmbH	Renolin Unisyn CLP		220 (-37)	320 (-34)
Klüber Lubrication	Klübersynth GEM 4		220 (-35)	320 (-35)
Kuwait Petroleum International	Q8 EL Greco		220 (-22)	320 (-19)
Lubrication Engineers Inc	Synolec Gear Lubricant		9920 (-40)	
Mobil Oil Company Limited	Mobilgear SHC		220 (-40)	320 (-37)
	Mobilgear SHC XMP	c	220 (-40)	320 (-33)
Optimol Ölwerke GmbH	Optigear Synthetic A		220 (-31)	320 (-31)
Petro-Canada	Super Gear Fluid	e	220 (-43)	320 (-37)
Shell Oils	Omala HD	c	220 (-43)	320 (-40)
Texaco Limited	Pinnacle EP		220 (-43)	320 (-33)
	Pinnacle WM	c	220 (-43)	320 (-43)
Total	Carter EP/HT		220 (-34)	320 (-31)
Tribol GmbH	Tribol 1510		220 (-36)	320 (-33)

**NOTES:**

- c) These lubricants have been tested for micro-pitting (FZG Type C), test results are available.
- e) These lubricants contain additives which may adversely affect silvered or white metal components; consult oil supplier.
- h) Minimum operating temperatures of these lubricants are based on worst case values, lower operating temperatures may be available, please check with local supplier.

**DANGER**

Numbers in brackets indicate recommended minimum operating temperature in °C

**THE UNIT MUST NOT RUN BELOW THIS TEMPERATURE**

# SERIES G

## STANDARD SHAFT SEALING ARRANGEMENTS

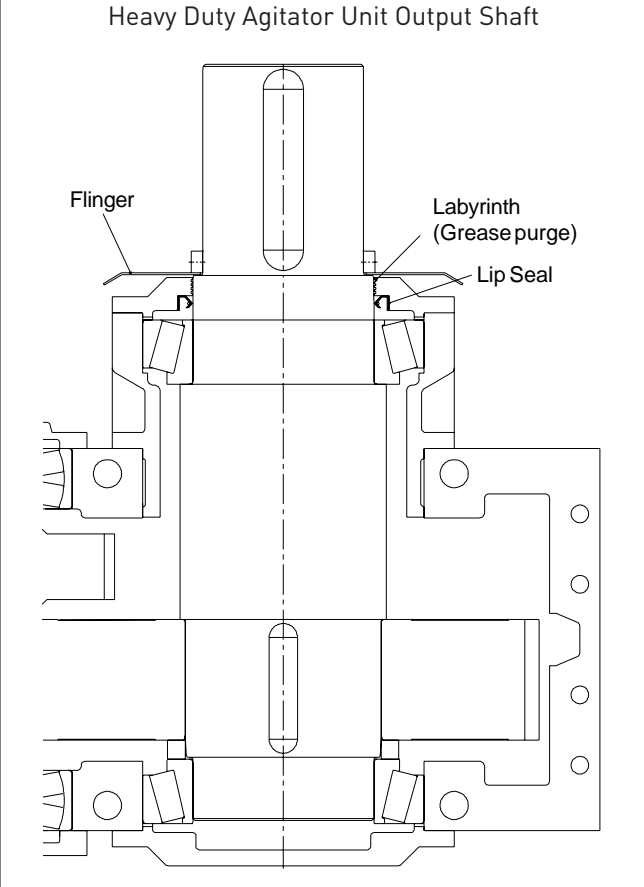
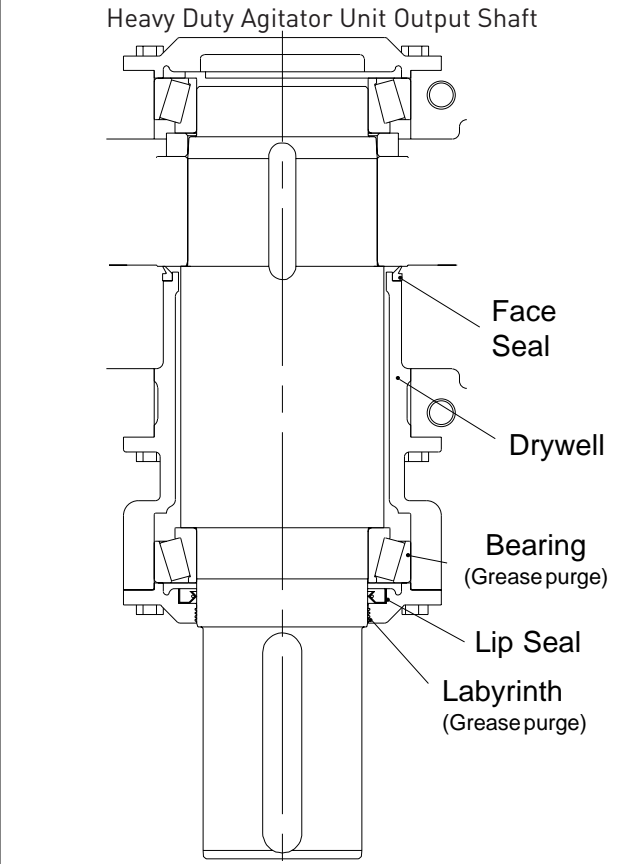
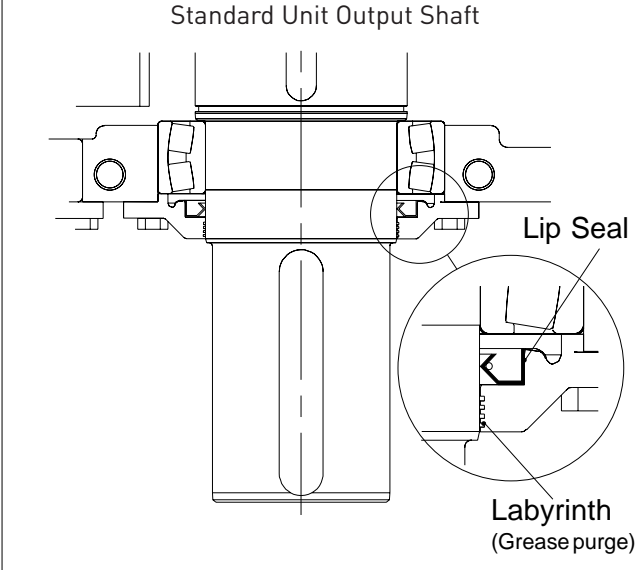
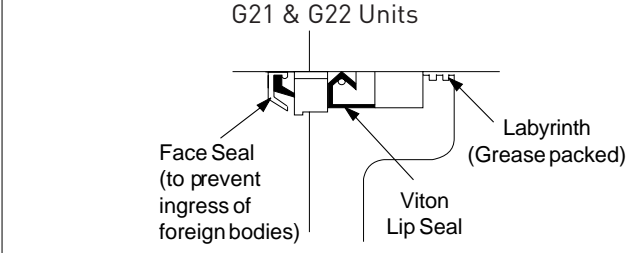
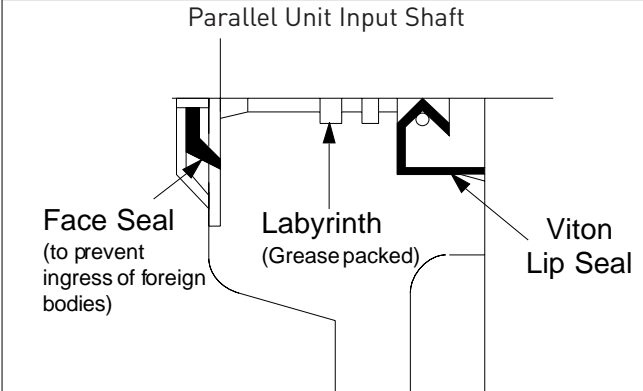
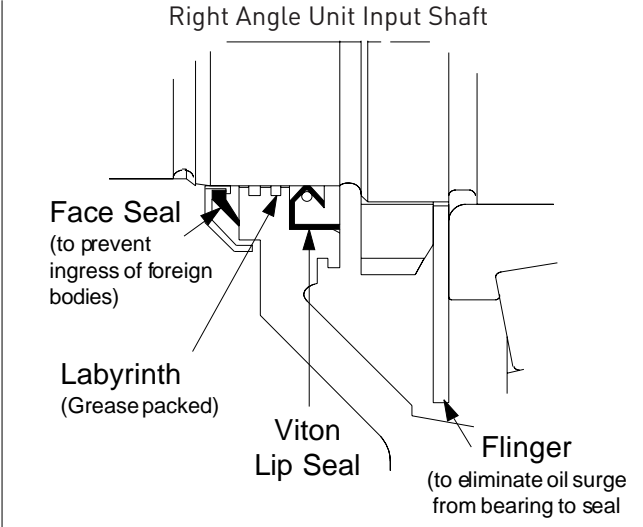

# SERIES G

## INPUT SHAFT OPTIONS

### INPUT SHAFT OPTIONS

\* Inch shaft has an open ended keyway, therefore no 'C' dimension is required.

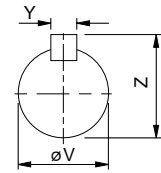
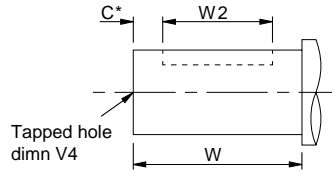

Column 11 Entry  
Inch

Single  N  
Double  P

Metric

Single  -  
Double  D

### Parallel Shaft Units

SIZE OF UNIT	TYPE OF INPUT SHAFT	NO OF REDUCTIONS	DIMENSIONS IN inchES (Metric Shaft in mm)						
			C*	øV	V4	W	W2	Y	Z
14 AND 15	Inch	2 Stage	-	1.8750" 1.8740"	5/8" UNF x 1.25 deep	5.31"	4.13"	0.500"	2.10"
		3 and 4 Stage	-	1.3750" 1.3745"	1/2" UNF x 1 deep	3.74"	3.00"	0.3125"	1.51"
16 AND 17	Inch	2 Stage	-	2.2500" 2.2490"	3/4" UNF x 1.62 deep	5.71"	4.13"	0.500"	2.47"
		3 and 4 Stage	-	1.7500" 1.7490"	5/8" UNF x 1.25 deep	4.53"	4.13"	0.375"	1.92"
18 AND 19	Inch	2 Stage	-	3.2500" 3.2490"	1" UNF x 2 deep	7.48"	5.88"	0.750"	3.58"
		3 and 4 Stage	-	2.2500" 2.2490"	3/4" UNF x 1.62 deep	5.71"	4.13"	0.500"	2.47"
21 AND 22	Inch	2 Stage	-	4.2500" 4.2490"	1" UNF x 2 deep	8.27"	7.5"	1.000"	4.69"
		3 and 4 Stage	-	3.0000" 2.9990"	3/4" UNF x 1.62 deep	7.48"	6.50"	0.750"	3.33"
14 AND 15	Metric	2 Stage	3	50.018 50.002	M16 x 36	138	130	14	53.5
		3 and 4 Stage	3	35.018 35.002	M12 x 25	99	90	10	38
16 AND 17	Metric	2 Stage	3	60.03 60.011	M20 x 43	148	140	18	64
		3 and 4 Stage	3	45.018 45.002	M16 x 36	118	110	14	48.5
18 AND 19	Metric	2 Stage	3	85.035 85.013	M24 x 52	190	180	22	90
		3 and 4 Stage	3	60.03 60.011	M20 x 43	150	140	18	64
21 AND 22	Metric	2 Stage	3	110.035 110.013	M30 x 63	210	200	28	116
		3 and 4 Stage	3	80.03 80.011	M20 x 43	190	180	22	85

### Right Angle Shaft Units

SIZE OF UNIT	TYPE OF INPUT SHAFT	NO OF REDUCTIONS	DIMENSIONS IN inchES (Metric Shaft in mm)						
			C*	øV	V4	W	W2	Y	Z
14 AND 15	Inch	3 Stage	-	1.5000" 1.4995"	5/8" UNF x 1.25 deep	3.94"	3.44"	0.375"	1.66"
16 AND 17	Inch	3 Stage	-	1.8750" 1.8740"	5/8" UNF x 1.25 deep	5.51"	4.13"	0.500"	2.10"
		4 Stage	-	1.5000" 1.4995"	5/8" UNF x 1.25 deep	3.94"	3.44"	0.375"	1.66"
18 AND 19	Inch	3 Stage	-	3.0000" 2.9990"	3/4" UNF x 1.62 deep	6.30"	5.25"	0.750"	3.33"
		4 Stage	-	1.8750" 1.8740"	5/8" UNF x 1.25 deep	5.51"	4.13"	0.500"	2.10"
21 AND 22	Inch	3 Stage	-	4.0000" 3.9990"	1" UNF x 2 deep	8.27"	7.5"	1.00"	4.44"
		4 Stage	-	3.0000" 2.9990"	3/4" UNF x 1.62 deep	6.30"	5.25"	0.750"	3.33"
14 AND 15	Metric	3 Stage	3	38.018 38.002	M12 x 32	100	90	10	41
16 AND 17	Metric	3 Stage	3	50.018 50.002	M16 x 36	140	130	14	53.5
		4 Stage	3	38.018 38.002	M12 x 32	100	90	10	41
18 AND 19	Metric	3 Stage	3	75.03 75.011	M20 x 43	160	150	20	79.5
		4 Stage	3	50.018 50.002	M16 x 36	140	130	14	53.5
21 AND 22	Metric	3 Stage	3	100.035 100.013	M24 x 52	210	200	28	106
		4 Stage	3	75.03 75.011	M20 x 43	160	150	20	79.5

# SERIES G

## OUTPUT SHAFT OPTIONS

### OUTPUT SHAFT OPTIONS

\* Inch shaft has an open ended keyway, therefore no 'C' dimension is required.

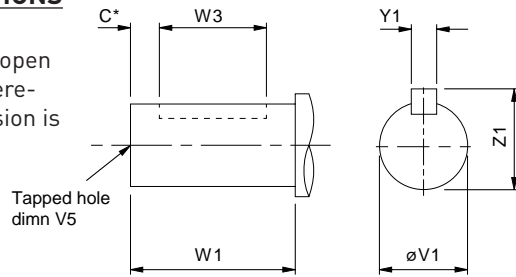

### Column 10 Entry

Inch

Single  L

Double  R

Agitator  S or  T

### Column 10 Entry

Metric

Single  F

Double  G

Agitator  A or  C

SIZE OF UNIT	TYPE OF OUTPUT SHAFT	DIMENSIONS IN mm (Inch Shaft in Inches)						
		C*	øV1	V5	W1	W3	Y1	Z1
14	Inch Single	-	4.500"	1" UNF x 2" deep	7.09"	6.50"	1.00"	4.94"
	Inch Double							
	Inch Agitator							
15	Inch Single	-	5.000"	1" UNF x 2" deep	7.48"	7.13"	1.25"	5.55"
	Inch Double							
	Inch Agitator							
16	Inch Single	-	6.000"	1.25" UNF x 2.5" deep	9.06"	8.75"	1.50"	6.66"
	Inch Double							
	Inch Agitator							
17	Inch Single	-	6.750"	1.25" UNF x 2.5" deep	9.84"	9.38"	1.75"	7.39"
	Inch Double							
	Inch Agitator							
18	Inch Single	-	7.500"	1.5" UNF x 3 deep	11.81"	11.38"	1.75"	8.15"
	Inch Double							
	Inch Agitator							
19	Inch Single	-	8.250"	1.5" UNF x 3 deep	13.78"	13.00"	2.00"	8.88"
	Inch Double							
	Inch Agitator							
21	Inch Single	-	8.500"	1.5" UNF x 3 deep	13.78"	13.00"	2.00"	9.13"
	Inch Double							
	Inch Agitator							
22	Inch Single	-	9.250"	1.5" UNF x 3 deep	14.96"	14.25"	2.5"	9.95"
	Inch Double							
	Inch Agitator							

14	Metric Single	5	110.035	M30 x 3.5 63 deep	180	170	28	116
	Metric Double							
	Metric Agitator							
15	Metric Single	5	130.04	M30 x 3.5 63 deep	190	180	32	137
	Metric Double							
	Metric Agitator							
16	Metric Single	5	145.04	M42 x 4.5 81 deep	230	220	36	153
	Metric Double							
	Metric Agitator							
17	Metric Single	5	170.04	M42 x 4.5 81 deep	250	240	40	179
	Metric Double							
	Metric Agitator							
18	Metric Single	5	190.046	M42 x 4.5 81 deep	300	290	45	200
	Metric Double							
	Metric Agitator							
19	Metric Single	5	210.046	M42 x 4.5 81 deep	350	340	50	221
	Metric Double							
	Metric Agitator							
21	Metric Single	5	220.046	M42 x 4.5 81 deep	350	340	50	231
	Metric Double							
	Metric Agitator							
22	Metric Single	5	240.046	M42 x 4.5 81 deep	380	340	56	252
	Metric Double							
	Metric Agitator							



# SERIES G

## OUTPUT BORE OPTIONS

### OUTPUT BORE OPTIONS

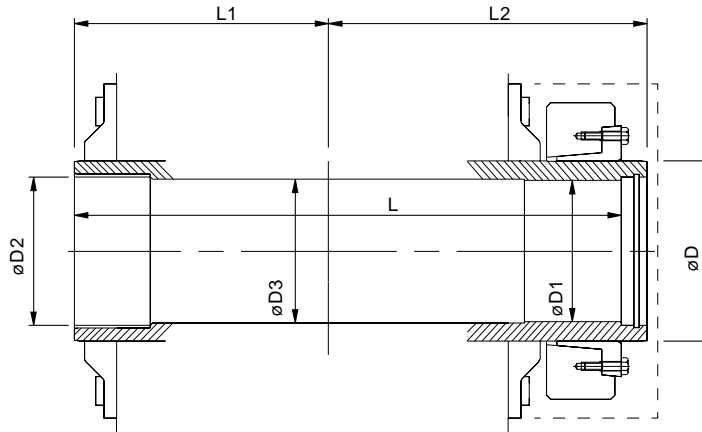

**Column 10 Entry \***

With Shrink Disk J

SIZE OF UNIT	TYPE OF OUTPUT BORE	DIMENSIONS IN inchES						
		$\varnothing D$	$\varnothing D1$	$\varnothing D2$	$\varnothing D3$	L	L1	L2
14	Standard with Shrink Disk	4.72	3.742	3.940	3.78	16.34	7.09	10.04
			3.740	3.937				
15	Standard with Shrink Disk	5.51	4.332	4.531	4.37	16.54	7.09	10.24
			4.331	4.528				
16	Standard with Shrink Disk	6.30	4.923	5.122	4.96	20.98	9.06	12.80
			4.921	5.118				
17	Standard with Shrink Disk	7.09	5.710	5.909	5.79	21.57	9.06	13.39
			5.709	5.906				
18	Standard with Shrink Disk	7.87	6.301	6.697	6.38	27.09	11.81	16.14
			6.299	6.693				
19	Standard with Shrink Disk	8.66	6.694	7.091	6.77	27.87	11.81	16.93
			6.693	7.087				
21	Standard with Shrink Disk	10.24	8.270	8.665	8.35	32.44	13.78	19.69
			8.268	8.661				
22	Standard with Shrink Disk	11.02	9.057	9.453	9.13	33.03	13.78	20.28
			9.055	9.449				

G

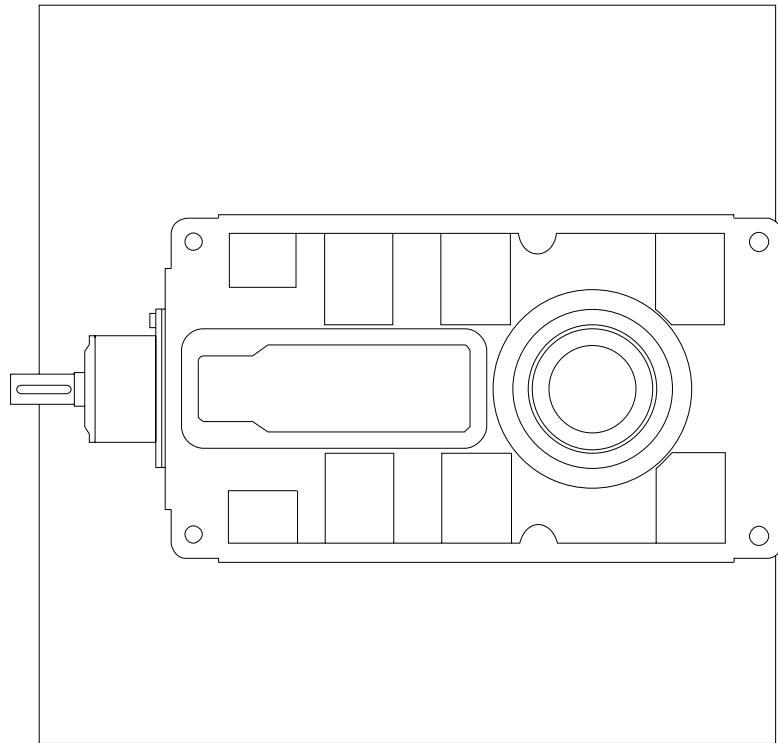

**REDUCER**  
**SERIES G**

### Maximum permissible overhung loads

When a sprocket, gear etc. is mounted on the shaft a calculation, as below, must be made to determine the overhung load on the shaft, and the results compared to the maximum permissible overhung loads tabulated. Overhung loads can be reduced by increasing the diameter of the sprocket, gear, etc. If the maximum permissible overhung load is exceeded, the sprocket, gear, etc. should be mounted on a separate shaft, flexibly coupled and supported in its own bearings, or the gear unit shaft should be extended to run in an outboard bearing. Alternatively, a larger gear is often a less expensive solution.

Permissible overhung loads vary according to the direction of rotation. The values tabulated are for the most unfavourable direction with the unit transmitting full rated power and the load P applied midway along the shaft extension. Hence they can sometimes be increased for a more favourable direction of rotation, or if the power transmitted is less than the rated capacity of the gear unit, or if the load is applied nearer to the gear unit case. Refer to our Application Engineers for further details. In any event, the sprocket, gear etc. should be positioned as close as possible to the gear unit case in order to reduce bearing loads and shaft stresses, and to prolong life.

All units will accept 100% momentary overload on stated capacities.

### Overhung load (lb's)

$$P = \frac{Hp \times 126\,000 \times K}{N \times D}$$

where

- P = equivalent overhung load (lb's)
- Hp = power transmitted by the shaft (Hp)
- N = speed of shaft (rev/min)
- D = pitch diameter of sprocket, etc. (in)
- K = factor

Note: 1 lb = 0.4536 kg = 4.4484 newtons.

### Overhung member K (factor)

Chain sprocket*	1.00
Spur or helical pinion	1.25
Vee belt sheave	1.50
Flat belt pulley	2.00

\* If multistrand chain drives are equally loaded and the outer strand is further than dimension A output or B input, refer to our Application Engineers.

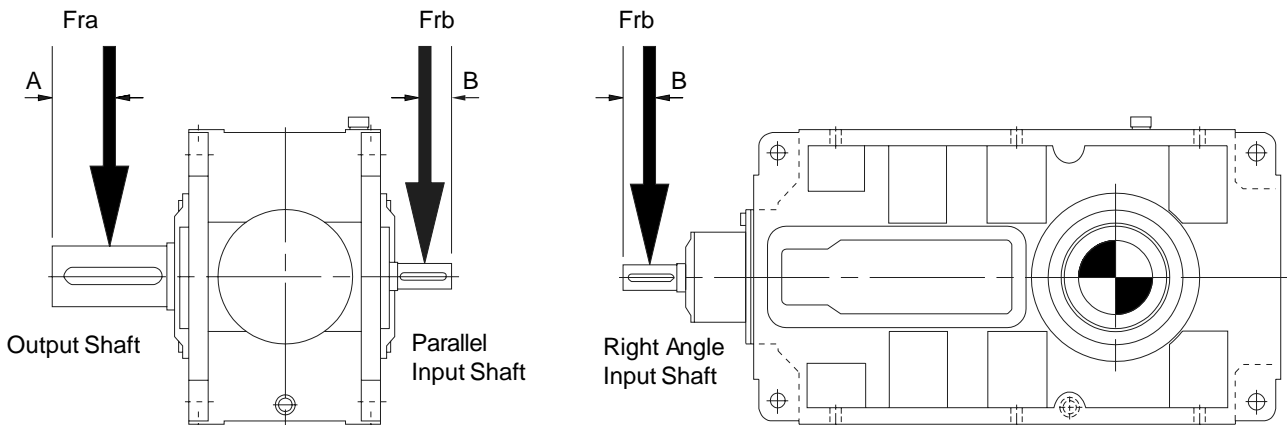

### Output Shaft - Distance 'A'

[midway along the shaft extension]

Size of unit	Dimension A (Inches)
G14	3.55"
G15	3.74"
G16	4.53"
G17	4.92"
G18	5.91"
G19	6.89"
G21	6.89"
G22	7.48"

### Input Shaft - Distance 'B'

[midway along the shaft extension]

Size of unit	Parallel Shaft Unit		Right Angle Shaft Unit	
	2 Stage	3 & 4 Stage	3 Stage	4 Stage
G14 and G15	2.66	1.87	1.97	-
G16 and G17	2.86	2.27	2.76	1.97
G18 and G19	3.74	2.86	3.15	2.76
G21 and G22	4.13	3.74	4.13	3.15

### Axial Thrust Capacities (lb's)

Permissible axial thrust capacities vary according to the direction of rotation and the direction of thrust, towards or away from the unit. The values tabulated are for the most unfavourable direction and hence can sometimes be increased. Similarly they can sometimes be increased if the power transmitted is less than the rated capacity of the gear unit.

Thrust capacities tabulated refer to output shaft, and are calculated without any overhung loads being applied. In cases where combined axial thrusts and overhung loads are to be applied, refer to our Application Engineers.

# SERIES G

## OVERHUNG & AXIAL LOADS ON SHAFTS

### OVERHUNG LOADS (Fra) ON OUTPUT SHAFT (lb-force)

Parallel Shaft Units                      Handings:      LR, RL, DL and DR  
 Right Angle Shaft Units                All handings with preferred shaft rotations

Shaft Speed (Rev/min)	Unit Size							
	14	15	16	17	18	19	21	22
< 240	5620	8990	9670	18430	19110	26080	29230	35970
< 180	6070	9670	10340	18430	19560	26080	29230	35970
< 130	6520	10570	11020	18430	20230	26080	29230	35970
< 90	7190	11240	11240	18430	21360	26080	29230	35970
< 45	7640	12360	12360	18430	24730	26080	44290	44290
< 20	6740	12360	12360	18430	26080	26080	61820	61820

### OVERHUNG LOADS (Fra) ON OUTPUT SHAFT (lb-force)

Parallel Shaft Units                      Handings:      LL and RR  
 Right Angle Shaft Units                All handings with non-preferred shaft rotations

Shaft Speed (Rev/min)	Unit Size							
	14	15	16	17	18	19	21	22
< 240	5620	7190	6290	13490	13490	17980	17980	17980
< 180	6070	7870	6520	13490	13710	17980	17980	17980
< 130	6520	8320	6970	13490	14160	17980	17980	17980
< 90	7190	8990	6970	13490	15290	17980	17980	17980
< 45	7640	10120	6970	13490	17980	17980	29230	29230
< 20	6970	10120	6970	13490	17980	17980	56200	56200

### AXIAL THRUST ON OUTPUT SHAFT (lb-force)

Shaft Speed (Rev/min)	Unit Size							
	14	15	16	17	18	19	21	22
< 240	1120	1910	1800	5620	3600	5850	5850	8090
< 180	1150	1930	1910	5620	3820	6070	6070	8090
< 130	1190	2230	2140	6070	4050	6740	6070	8090
< 90	1390	2700	2250	6520	4270	7640	6070	8090
< 45	2470	4500	3370	8990	8090	10120	8320	8320
< 20	4270	7190	5620	14610	14610	14610	17980	195603370

### OVERHUNG LOADS (Frb) ON INPUT SHAFT (lb-force)

Unit Type		Unit Size							
		14	15	16	17	18	19	21	22
Parallel Shaft	2 Stage	3370	3370	4950	4950	8770	8770	15740	15740
	3 and 4 Stage	1550	1550	2050	2050	3600	3600	5620	5620
Right Angle	3 Stage	2470	2470	3600	3600	9220	9220	12590	12590
	4 Stage	-	-	2470	2470	3600	3600	9220	9220



# SERIES G

## AGITATOR APPLICATIONS BENDING MOMENT CAPACITY

To calculate the Bending Moment on the gearbox output shaft using the method recommended in The Engineering Equipment Users' Association Handbook No. 9:-

$$\text{Bending Moment (lb.in)} = \frac{\text{Absorbed Power (hp)} \times 63000}{\text{Shaft Speed} \times 0.75 R}$$

The above information is given for guidance. When more precise bending moment values are available they should be used.

Check the Bending Moment Capacity of the Gearbox  
Agitator units are suitable for supporting a paddle directly coupled to the gearbox output shaft and for accepting the bending moments and axial thrusts generated from the forces at the paddle. Agitator type units have an extended bearing span and taper bearings to accept higher loads than the standard unit.

Check the Bending Moment Capacity limited by shaft stress, using Table 2.

Check the Bending Moment Capacity limited by bearing life, using Table 3.

Note: Bearing Capacities are based on 10,000 hours, L10 life.  
For other bearing lives multiply the values in Table 3 by factors in Table 1.

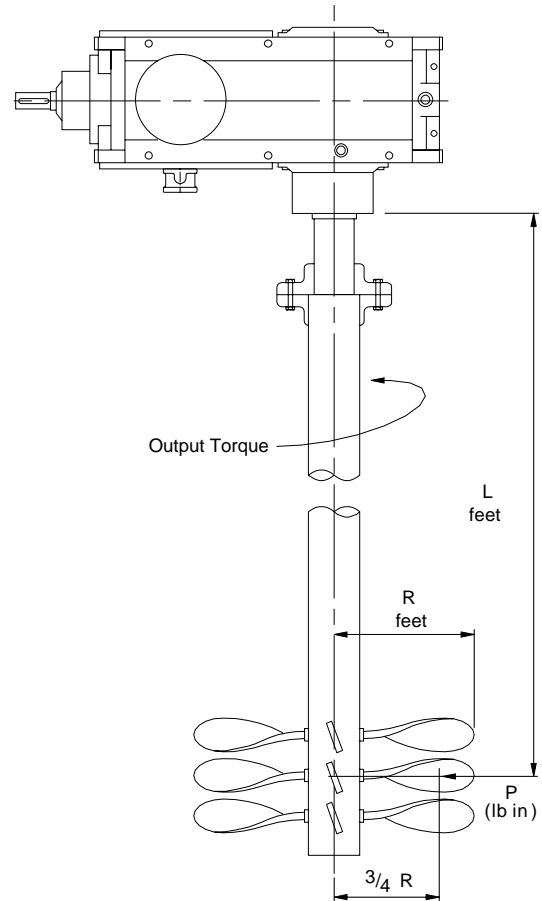

**Table 1 Bearing Life Factors ( $F_B$ )**

	Required Life (hours)				
	5000	10000	25000	50000	100000
Factor	1.23	1	0.76	0.62	0.50
For intermediate values					
$F_B = \left( \frac{10000}{\text{Required Life (hours)}} \right)^{0.3}$					

**Table 2 Bending Moment Capacity (lb-force)**

Allowable Bending Moment at output shaft lower bearing, limited by SHAFT STRESS

Unit Type	Unit Size							
	14	15	16	17	18	19	21	22
Agitator Units	99130	153120	214190	330130	442540	601850	902780	**

**Table 3 Bending Moment Capacity (lb-force)**

Allowable Bending Moment on output shaft bearings, limited by BEARING LIFE (10,000 hrs L10)\*

Unit Type	Output Speed rev/min	UNIT SIZE							
		14	15	16	17	18	19	21	22
Agitator Units	< 240	52220	96470	101780	227460	238090	325710	354030	**
	< 180	65500	114170	128340	266410	298270	398280	469090	
	< 130	93820	148690	187640	344290	431920	539900	743460	
	< 90	101780	162850	202680	377040	469090	601850	805420	
	< 45	146920	223040	294730	486790	646110	787720	1177150	
	< 20	213300	291190	413330	628400	858520	1035540	1557730	

\* For other lives multiply values by the factors in table 1

\*\* Consult Application Engineering

# SERIES G

## AGITATOR APPLICATIONS AXIAL THRUST LOADS

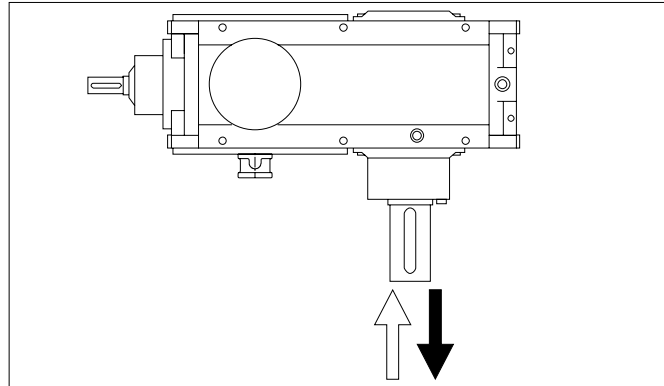

**Table 4 Axial thrust capacity (lb-force)**

Allowable thrust on output shaft, limited by COVER BOLT STRESS

Unit Type	Unit Size							
	14	15	16	17	18	19	21	22
Agitator Units	6740	8990	12360	14610	14610	14610	33720	**

Note: The values in table 4 are calculated for the most adverse direction of rotation. For the opposite rotation they can be increased. Consult our Application Engineers for an analysis where necessary.

**Table 5 Axial thrust capacity (lb-force)**

Allowable thrust on output shaft, limited by BEARING LIFE (10,000 hrs L10)\*

Direction Of Thrust	Unit Type	Output Speed rev/min	Unit Size							
			14	15	16	17	18	19	21	22
↑	Agitator Units	< 240	3150	5850	5170	11470	8990	12360	12590	**
		< 180	3150	6070	5400	11690	9220	12590	13040	
		< 130	3370	5850	5620	11690	9220	12810	13040	
		< 90	3600	6740	6290	12810	10340	14160	14840	
		< 45	5850	9670	10120	18210	16860	21810	24730	
		< 20	8990	14160	15740	26080	25850	32820	39340	
↓	Agitator Units	< 240	2250	4950	3820	9890	6970	10120	8990	**
		< 180	2470	5170	4050	10120	7190	10120	9220	
		< 130	2470	5400	4050	10340	7190	10570	9220	
		< 90	2920	5620	4720	11240	8320	11910	11240	
		< 45	5170	8770	8540	16640	14610	19330	20910	
		< 20	8090	12590	14390	24730	23830	30350	35300	

\* For other lives multiply values by the factors in table 1 page 29.

\*\* Consult Application Engineering

Note: Values are based on the most unfavourable directions of rotation. Higher values may be permitted after analysis by our Application Engineers.



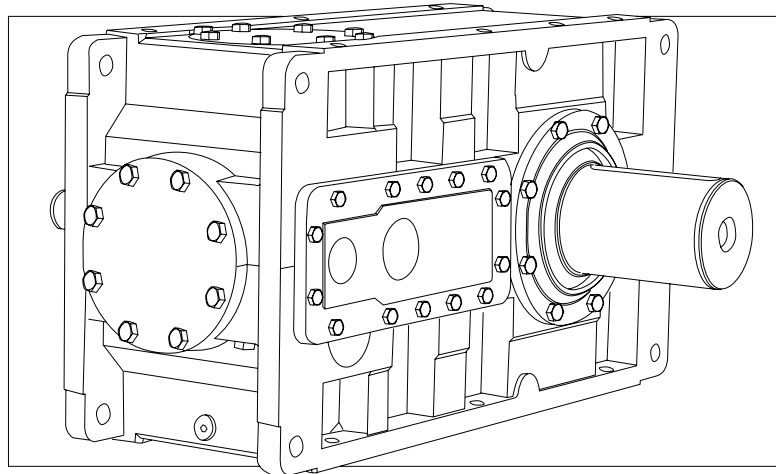

G

## PARALLEL SHAFT UNITS



# SERIES G

## MOMENTS OF INERTIA PARALLEL SHAFT UNITS

### MOMENTS OF INERTIA (lb in<sup>2</sup>) Referred to Input Shaft

#### PARALLEL SHAFT UNITS - without fans

NOMINAL RATIO COLUMN ENTRY	PARALLEL SHAFT UNITS - SIZE								
	G14	G15	G16	G17	G18	G19	G21	G22	
6.3	140	-	486	-	2281	-	-	-	DOUBLE REDUCTION
7.1	115	-	451	-	1970	-	7866	-	
8.0	101	166	390	604	1589	2722	6840	8615	
9.0	87	135	333	554	1371	2346	5985	7490	
10.	78	118	286	479	1277	1878	5198	6430	
11.	68	103	239	398	1105	1602	4412	5609	
12.	58	89	200	337	855	1474	3865	4754	
14.	50	75	166	282	799	1260	3280	4104	
16.	43	65	152	236	665	978	2753	3488	
18.	36	56	142	193	592	893	2562	2900	
20.	34	46	130	173	569	735	2267	2688	
22.	31	39	120	157	523	653	2097	2363	TRIPLE REDUCTION
25.	29	36	109	144	460	619	1932	2175	
28.	27	33	101	130	446	564	1801	1994	
32.	25	30	100	118	410	489	1688	1847	
36.	15	28	51	108	209	470	1630	1724	
40.	13	26	48	106	203	428	819	1659	
45.	13	15	45	56	192	224	776	845	
50.	12	14	43	51	176	215	735	797	
56.	12	13	41	48	173	202	701	749	
63.	11	13	40	46	162	183	674	715	
71.	11	12	38	43	149	178	658	681	
80.	11	12	37	42	147	168	571	667	
90.	10	11	37	39	142	152	556	624	QUADRUPLE REDUCTION
100	10	11	31	38	125	149	547	58	
112	10	11	31	38	123	145	445	599	
125	10	10	31	32	120	125	438	496	
140	6	10	19	31	86	123	434	486	
160	6	10	18	31	77	121	287	482	
180	6	6	18	21	75	86	250	328	
200	6	6	18	18	75	77	246	287	
225	-	6	-	18	-	75	245	286	
250	-	6	-	18	-	75	-	284	



#### PARALLEL SHAFT UNITS - with fans

If fan cooling is required the inertia of the fan must be added to the table above.

#### MOMENTS OF INERTIA of fans (lb in<sup>2</sup>)

	G14/G15	G16/G17	G18/G19	G21
DOUBLE REDUCTION	97	253	808	1676
TRIPLE REDUCTION	N/A	97	253	808

$GD^2$  (lb in<sup>2</sup>) = 4 x Moment of Inertia (lb in<sup>2</sup>)

# SERIES G

## EXACT RATIOS PARALLEL SHAFT UNITS

### EXACT RATIOS - PARALLEL SHAFT UNITS

#### Double Reduction

Nominal Ratio Column Entry  6   7   8	UNIT - SIZE							
	G14	G15	G16	G17	G18	G19	G21	G22
6.3	6.1	-	6.528	-	6.324	-	-	-
7.1	7.029	-	7.06	-	6.986	-	7.36	-
8.0	7.752	7.7	7.729	8.393	8.016	7.93	8.153	8.221
9.0	8.578	8.873	8.82	9.078	8.935	8.76	9.221	9.106
10.	9.531	9.785	9.929	9.938	9.765	10.051	10.104	10.293
11.	10.643	10.828	11.063	11.34	10.957	11.204	11.324	11.285
12.	11.957	12.031	12.641	12.766	12.797	12.245	12.765	12.647
14.	13.534	13.435	14.36	14.223	14.092	13.739	14.494	14.257
16.	15.462	15.094	15.504	16.253	15.982	16.047	16.608	16.188
18.	-	17.084	-	18.463	-	17.671	17.851	18.549
20.	-	19.517	-	19.934	-	20.04	-	19.938

#### Triple Reduction

Nominal Ratio Column Entry  6   7   8	UNIT - SIZE							
	G14	G15	G16	G17	G18	G19	G21	G22
18.	17.401	-	17.934	-	17.539	-	-	-
20.	19.335	-	20.19	-	19.168	-	20.569	-
22.	21.591	21.966	22.494	23.058	21.507	21.994	23.051	22.973
25.	24.256	24.406	25.704	25.958	25.12	24.036	25.985	25.746
28.	27.455	27.254	29.199	28.921	27.662	26.969	29.506	29.023
32.	31.365	30.619	31.525	33.048	31.371	31.499	33.809	32.955
36.	34.721	34.657	35.77	37.542	35.182	34.688	36.34	37.761
40.	38.579	39.592	40.269	40.532	38.45	39.339	41.011	40.587
45.	43.08	43.828	44.865	45.99	43.141	44.117	45.96	45.804
50.	48.399	48.698	51.268	51.774	50.388	48.215	51.81	51.332
56.	54.782	54.379	58.239	57.683	55.488	54.098	58.829	57.865
63.	62.583	61.094	62.877	65.916	62.928	63.185	67.408	65.705
71.	-	69.151	-	74.879	-	69.58	72.455	75.287
80.	-	78.999	-	80.842	-	78.909	-	80.924

#### Quadruple Reduction

Nominal Ratio Column Entry  6   7   8	UNIT - SIZE							
	G14	G15	G16	G17	G18	G19	G21	G22
71.	70.494	-	71.59	-	73.105	-	-	-
80.	78.327	-	81.324	-	80.504	-	79.169	-
90.	87.465	88.984	87.8	92.044	91.298	91.671	90.715	88.423
100	98.265	98.872	104.001	104.559	102.455	100.949	97.506	101.318
112	111.224	110.407	118.142	112.886	112.825	114.485	115.479	108.903
125	127.063	124.039	127.55	133.716	127.953	128.475	132.32	128.977
140	136.419	140.398	140.233	151.897	140.825	141.479	142.226	147.786
160	153.263	160.392	166.109	163.993	158.034	160.449	159.476	158.85
180	173.476	172.201	188.694	180.299	174.029	176.59	188.872	178.116
200	198.181	193.464	203.721	213.568	197.364	198.17	216.416	210.948
225	-	218.978	-	242.607	-	218.227	232.618	241.712
250	-	250.163	-	261.927	-	247.488	-	259.808

# SERIES G

## PARALLEL SHAFT UNIT MECHANICAL RATINGS AT 1750 RPM INPUT

Nominal Ratio Column Entry	Nominal Output Speed RPM	Mechanical Capacity	PARALLEL SHAFT UNITS - SIZE								
			G14	G15	G16	G17	G18	G19	G21	G22	
6.3	278	Input power - HP	390	-	740	-	1680	-	-	-	DOUBLE REDUCTION
		Output torque - lb-in	82600	-	169000	-	374400	-	-	-	
7.1	246	Input power - HP	350	-	720	-	1570	-	<b>3020</b>	-	
		Output torque - lb-in	85700	-	177000	-	388500	-	<b>787700</b>	-	
8.0	219	Input power - HP	320	390	670	740	1420	1680	<b>3020</b>	<b>3020</b>	
		Output torque - lb-in	87900	105300	180500	217700	401800	469100	<b>867300</b>	<b>878800</b>	
9.0	194	Input power - HP	300	350	620	720	1320	1570	3020	<b>3020</b>	
		Output torque - lb-in	90300	108900	191200	228300	416000	486800	973500	<b>973500</b>	
10	175	Input power - HP	280	330	570	670	1270	1420	2880	3020	
		Output torque - lb-in	92000	112400	197400	231900	438100	504500	1026600	1097400	
11	156	Input power - HP	250	300	520	620	1170	1320	2660	2880	
		Output torque - lb-in	92900	115100	200900	245100	451400	522200	1053200	1150500	
12	140	Input power - HP	230	280	490	570	1020	1270	2430	2660	
		Output torque - lb-in	94700	116800	216800	254000	457500	549600	1088600	1185900	
14	125	Input power - HP	200	250	420	520	970	1170	2190	2440	
		Output torque - lb-in	95600	118600	210600	258400	478800	566400	1106300	1230200	
16	109.4	Input power - HP	180	230	400	500	870	1020	1970	2190	
		Output torque - lb-in	97400	120400	214200	282300	485000	574400	1150500	1247900	
18	97.2	Input power - HP	160	210	320	420	760	970	1820	2020	
		Output torque - lb-in	93800	120400	198200	270800	466400	600900	1150500	1318700	
20	87.5	Input power - HP	140	180	310	400	760	870	1590	1920	
		Output torque - lb-in	97400	123900	214200	275200	508900	608900	1150500	1345200	
22	79.5	Input power - HP	130	160	280	320	690	760	1420	1610	
		Output torque - lb-in	97400	117700	218600	254900	512400	585000	1150500	1301000	
25	70.0	Input power - HP	120	140	260	320	600	760	1260	1580	
		Output torque - lb-in	97400	121200	226600	286700	518600	639000	1150500	1424900	
28	62.5	Input power - HP	110	130	230	310	540	690	1110	1410	
		Output torque - lb-in	97400	122100	226600	308900	518600	679700	1150500	1424900	
32	54.7	Input power - HP	90	120	210	270	480	640	970	1240	
		Output torque - lb-in	97400	123000	226600	311500	518600	700000	1150500	1424900	
36	48.6	Input power - HP	80	100	180	240	410	580	910	1090	
		Output torque - lb-in	97400	123900	226600	312400	518600	700000	1150500	1424900	
40	43.8	Input power - HP	70	90	160	220	390	510	800	1010	
		Output torque - lb-in	97400	123900	226600	313300	518600	700900	1150500	1424900	
45	38.9	Input power - HP	70	80	150	190	350	410	720	900	
		Output torque - lb-in	97400	119500	226600	304400	518600	620400	1150500	1424900	
50	35.0	Input power - HP	60	70	130	170	300	410	640	800	
		Output torque - lb-in	96500	121200	226600	307100	518600	677900	1150500	1424900	
56	31.3	Input power - HP	50	70	110	160	270	380	560	710	
		Output torque - lb-in	97400	122100	226600	308900	518600	700900	1150500	1424900	
63	27.8	Input power - HP	50	60	110	140	240	320	490	630	
		Output torque - lb-in	97400	123900	226600	311500	518600	700900	1150500	1424900	
71	24.6	Input power - HP	40	50	90	120	180	290	460	550	
		Output torque - lb-in	94700	123900	226600	312400	455800	700900	1150500	1424900	
80	21.9	Input power - HP	40	50	80	110	170	260	420	510	
		Output torque - lb-in	95600	123900	226600	313300	471700	700900	1150500	1424900	
90	19.4	Input power - HP	30	40	80	90	160	210	370	470	
		Output torque - lb-in	96500	117700	226600	296500	492100	640700	1150500	1433700	
100	17.5	Input power - HP	30	30	60	80	140	190	340	410	
		Output torque - lb-in	97400	118600	226600	299100	504500	665500	1150500	1433700	
112	15.6	Input power - HP	30	30	60	80	140	180	290	380	
		Output torque - lb-in	97400	120400	226600	303600	518600	693800	1150500	1433700	
125	14.0	Input power - HP	20	30	50	70	120	160	250	330	
		Output torque - lb-in	97400	122100	226600	302700	518600	701800	1150500	1433700	
140	12.5	Input power - HP	20	20	50	60	110	150	240	280	
		Output torque - lb-in	97400	123900	226600	302700	518600	701800	1150500	1433700	
160	10.9	Input power - HP	20	20	40	50	100	130	210	270	
		Output torque - lb-in	97400	123900	226600	303600	518600	701800	1150500	1433700	
180	9.7	Input power - HP	20	20	40	50	90	120	180	240	
		Output torque - lb-in	97400	123900	226600	303600	518600	701800	1150500	1433700	
200	8.8	Input power - HP	10	20	30	40	80	100	160	200	
		Output torque - lb-in	97400	123900	226600	302700	518600	701800	1150500	1433700	
225	7.8	Input power - HP	-	20	-	40	-	100	140	170	
		Output torque - lb-in	-	123900	-	302700	-	701800	1150500	1433700	
250	7.0	Input power - HP	-	10	-	30	-	80	-	160	
		Output torque - lb-in	-	123900	-	302700	-	701800	-	1433700	



**Bold Text: Forced lubrication System Required**

# SERIES G

## PARALLEL SHAFT UNIT MECHANICAL RATINGS AT 1450 RPM INPUT

Nominal Ratio Column Entry	Nominal Output Speed RPM	Mechanical Capacity	PARALLEL SHAFT UNITS - SIZE								
			G14	G15	G16	G17	G18	G19	G21	G22	
6.3	230	Input power - HP	340	-	650	-	1460	-	-	-	DOUBLE REDUCTION
		Output torque - lb-in	87300	-	178800	-	395600	-	-	-	
7.1	204	Input power - HP	310	-	630	-	1380	-	2490	-	
		Output torque - lb-in	90300	-	187600	-	410600	-	787700	-	
8.0	181	Input power - HP	280	340	580	650	1250	14620	2490	2490	
		Output torque - lb-in	92000	111500	191200	230100	424800	496500	867300	878800	
9.0	161	Input power - HP	260	310	540	630	1160	1380	2490	2490	
		Output torque - lb-in	92900	115900	201800	240700	439800	515100	973500	973500	
10	145	Input power - HP	230	290	500	580	1120	1250	2490	2490	
		Output torque - lb-in	93800	117700	208900	245100	462900	532800	1079700	1097400	
11	129	Input power - HP	210	260	450	540	1030	1160	2360	2490	
		Output torque - lb-in	95600	119500	212400	259300	477000	551400	1141700	1203600	
12	116	Input power - HP	190	240	420	500	890	1120	2110	2330	
		Output torque - lb-in	96500	120400	223000	269000	484100	580600	1150500	1256700	
14	104	Input power - HP	170	210	370	450	850	1030	1850	2130	
		Output torque - lb-in	97400	122100	223000	272600	506200	598300	1150500	1301000	
16	90.6	Input power - HP	150	190	350	430	760	890	1620	1920	
		Output torque - lb-in	97400	123000	226600	293800	513300	607100	1150500	1318700	
18	80.6	Input power - HP	130	170	280	370	670	850	1520	1740	
		Output torque - lb-in	93800	123900	209700	286700	492900	635400	1150500	1371800	
20	72.5	Input power - HP	120	150	270	350	650	760	1320	1640	
		Output torque - lb-in	97400	123900	226600	291200	518600	643400	1150500	1380600	
22	65.9	Input power - HP	110	130	240	280	580	670	1180	1390	
		Output torque - lb-in	97400	118600	226600	269000	518600	619500	1150500	1345200	
25	58.0	Input power - HP	100	120	210	280	490	670	1050	1310	
		Output torque - lb-in	97400	121200	226600	303600	518600	675300	1150500	1424900	
28	51.8	Input power - HP	90	110	190	260	450	600	920	1170	
		Output torque - lb-in	97400	122100	226600	308900	518600	679700	1150500	1424900	
32	45.3	Input power - HP	80	100	170	230	400	530	810	1030	
		Output torque - lb-in	97400	123000	226600	311500	518600	700000	1150500	1424900	
36	40.3	Input power - HP	70	90	150	200	360	480	750	900	
		Output torque - lb-in	97400	123900	226600	312400	518600	700000	1150500	1424900	
40	36.3	Input power - HP	60	80	140	190	320	430	670	840	
		Output torque - lb-in	97400	123900	226600	313300	518600	700900	1150500	1424900	
45	32.2	Input power - HP	50	70	120	160	290	360	600	750	
		Output torque - lb-in	97400	119500	226600	304400	518600	656700	1150500	1424900	
50	29.0	Input power - HP	50	60	110	140	250	350	530	670	
		Output torque - lb-in	97400	121200	226600	307100	518600	700900	1150500	1424900	
56	25.9	Input power - HP	40	50	90	130	230	310	470	590	
		Output torque - lb-in	97400	122100	226600	308900	518600	700900	1150500	1424900	
63	23.0	Input power - HP	40	50	90	110	200	270	410	520	
		Output torque - lb-in	97400	123900	226600	311500	518600	700900	1150500	1424900	
71	20.4	Input power - HP	30	40	80	100	160	240	380	460	
		Output torque - lb-in	94700	123900	226600	312400	482300	700900	1150500	1424900	
80	18.1	Input power - HP	30	40	70	90	150	210	350	430	
		Output torque - lb-in	95600	123900	226600	313300	499100	700900	1150500	1433700	
90	16.1	Input power - HP	30	30	60	80	140	180	310	390	
		Output torque - lb-in	96500	117700	226600	302700	518600	677900	1150500	1433700	
100	14.5	Input power - HP	20	30	50	70	120	170	290	340	
		Output torque - lb-in	97400	118600	226600	302700	518600	701800	1150500	1433700	
112	12.9	Input power - HP	20	30	50	70	110	150	240	320	
		Output torque - lb-in	97400	120400	226600	302700	518600	701800	1150500	1433700	
125	11.6	Input power - HP	20	20	40	60	100	130	210	270	
		Output torque - lb-in	97400	122100	226600	302700	518600	701800	1150500	1433700	
140	10.4	Input power - HP	20	20	40	50	90	120	200	240	
		Output torque - lb-in	97400	123900	226600	302700	518600	701800	1150500	1433700	
160	9.1	Input power - HP	20	20	30	50	80	110	180	220	
		Output torque - lb-in	97400	123900	226600	302700	518600	701800	1150500	1433700	
180	8.1	Input power - HP	10	20	30	40	70	100	150	200	
		Output torque - lb-in	97400	123900	226600	302700	518600	701800	1150500	1433700	
200	7.3	Input power - HP	10	10	30	30	60	90	130	170	
		Output torque - lb-in	97400	123900	226600	302700	518600	701800	1150500	1433700	
225	6.4	Input power - HP	-	10	-	30	-	80	120	140	
		Output torque - lb-in	-	123900	-	302700	-	701800	1150500	1433700	
250	5.8	Input power - HP	-	10	-	30	-	70	-	140	
		Output torque - lb-in	-	123900	-	302700	-	701800	-	1433700	

# SERIES G

## PARALLEL SHAFT UNIT MECHANICAL RATINGS AT 1160 RPM INPUT

Nominal Ratio Column Entry	Nominal Output Speed RPM	Mechanical Capacity	PARALLEL SHAFT UNITS - SIZE								
			G14	G15	G16	G17	G18	G19	G21	G22	
6.3	184	Input power - HP	290	-	550	-	1260	-	-	-	DOUBLE REDUCTION
		Output torque - lb-in	92000	-	191200	-	422100	-	-	-	
7.1	163	Input power - HP	250	-	540	-	1180	-	2000	-	
		Output torque - lb-in	93800	-	200000	-	438100	-	787700	-	
8.0	145	Input power - HP	230	280	500	550	1070	1260	2000	2000	
		Output torque - lb-in	94700	115100	203600	246000	453100	529200	867300	877900	
9.0	129	Input power - HP	210	250	460	540	990	1180	2000	2000	
		Output torque - lb-in	96500	117700	215900	257500	469100	549600	973500	973500	
10	116	Input power - HP	190	230	430	500	960	1070	2000	2000	
		Output torque - lb-in	97400	118600	223000	262000	493800	569100	1079700	1097400	
11	104	Input power - HP	170	210	390	460	880	990	1890	2000	
		Output torque - lb-in	97400	119500	226600	277000	509800	588500	1141700	1203600	
12	93	Input power - HP	160	190	340	430	760	960	1690	2000	
		Output torque - lb-in	97400	121200	226600	286700	516800	619500	1150500	1345200	
14	83	Input power - HP	140	170	300	390	700	880	1490	1810	
		Output torque - lb-in	97400	122100	226600	292100	518600	639900	1150500	1371800	
16	72.5	Input power - HP	120	150	280	350	620	760	1300	1600	
		Output torque - lb-in	97400	123000	226600	303600	518600	647800	1150500	1371800	
18	64.4	Input power - HP	100	140	240	320	570	730	1210	1430	
		Output torque - lb-in	94700	123900	223900	306200	518600	678800	1150500	1407200	
20	58.0	Input power - HP	100	120	220	300	520	650	1060	1350	
		Output torque - lb-in	97400	123900	226600	311500	518600	686800	1150500	1424900	
22	52.7	Input power - HP	90	100	190	240	460	570	940	1160	
		Output torque - lb-in	97400	119500	226600	288500	518600	655800	1150500	1407200	
25	46.4	Input power - HP	80	90	170	230	400	560	840	1050	
		Output torque - lb-in	97400	121200	226600	307100	518600	700000	1150500	1424900	
28	41.4	Input power - HP	70	90	150	210	360	500	740	940	
		Output torque - lb-in	97400	122100	226600	308900	518600	700000	1150500	1424900	
32	36.3	Input power - HP	60	80	140	180	320	430	650	830	
		Output torque - lb-in	97400	123000	226600	311500	518600	700900	1150500	1424900	
36	32.2	Input power - HP	50	70	120	160	280	390	600	720	
		Output torque - lb-in	97400	123900	226600	312400	518600	700900	1150500	1424900	
40	29.0	Input power - HP	50	60	110	150	260	340	540	670	
		Output torque - lb-in	97400	123900	226600	313300	518600	700900	1150500	1424900	
45	25.8	Input power - HP	40	50	100	130	230	310	480	600	
		Output torque - lb-in	97400	119500	226600	304400	518600	700900	1150500	1424900	
50	23.2	Input power - HP	40	50	90	110	200	280	430	540	
		Output torque - lb-in	97400	121200	226600	307100	518600	700900	1150500	1424900	
56	20.7	Input power - HP	40	40	80	100	180	250	370	470	
		Output torque - lb-in	97400	122100	226600	308900	518600	700900	1150500	1433700	
63	18.4	Input power - HP	30	40	70	90	160	210	330	420	
		Output torque - lb-in	97400	123900	226600	311500	518600	701800	1150500	1433700	
71	16.3	Input power - HP	30	30	60	80	140	190	300	370	
		Output torque - lb-in	94700	123900	226600	312400	516000	701800	1150500	1433700	
80	14.5	Input power - HP	20	30	50	70	130	170	280	340	
		Output torque - lb-in	95600	123900	226600	313300	518600	701800	1150500	1433700	
90	12.9	Input power - HP	20	30	50	60	110	150	250	310	
		Output torque - lb-in	96500	117700	226600	302700	518600	701800	1150500	1433700	
100	11.6	Input power - HP	20	20	40	60	100	140	230	270	
		Output torque - lb-in	97400	118600	226600	303600	518600	701800	1150500	1433700	
112	10.4	Input power - HP	20	20	40	50	90	120	190	260	
		Output torque - lb-in	97400	120400	226600	303600	518600	701800	1150500	1433700	
125	9.3	Input power - HP	20	20	30	40	80	110	170	220	
		Output torque - lb-in	97400	122100	226600	302700	518600	701800	1150500	1433700	
140	8.3	Input power - HP	10	20	30	40	70	100	160	190	
		Output torque - lb-in	97400	123900	226600	302700	518600	701800	1150500	1433700	
160	7.3	Input power - HP	10	10	30	40	60	90	140	180	
		Output torque - lb-in	97400	123900	226600	303600	518600	701800	1150500	1433700	
180	6.4	Input power - HP	10	10	20	30	60	80	120	160	
		Output torque - lb-in	97400	123900	226600	303600	518600	701800	1150500	1433700	
200	5.8	Input power - HP	10	10	20	30	50	70	100	130	
		Output torque - lb-in	97400	123900	226600	302700	518600	701800	1150500	1433700	
225	5.2	Input power - HP	-	10	-	20	-	60	100	120	
		Output torque - lb-in	-	123900	-	302700	-	701800	1150500	1433700	
250	4.6	Input power - HP	-	10	-	20	-	60	-	110	
		Output torque - lb-in	-	123900	-	302700	-	701800	-	1433700	



# SERIES G

## PARALLEL SHAFT UNIT MECHANICAL RATINGS AT 875 RPM INPUT

Nominal Ratio Column Entry	Nominal Output Speed RPM	Mechanical Capacity	PARALLEL SHAFT UNITS - SIZE								
			G14	G15	G16	G17	G18	G19	G21	G22	
6.3	139	Input power - HP	220	-	430	-	1000	-	-	-	DOUBLE REDUCTION
		Output torque - lb-in	92000	-	197400	-	446000	-	-	-	
7.1	123	Input power - HP	190	-	430	-	940	-	1510	-	
		Output torque - lb-in	93800	-	211500	-	462900	-	787700	-	
8.0	109	Input power - HP	170	210	400	430	850	1000	1510	1520	
		Output torque - lb-in	95600	115100	215900	253100	479700	559300	867300	877000	
9.0	97	Input power - HP	160	190	370	430	790	940	1510	1520	
		Output torque - lb-in	96500	117700	225700	272600	496500	580600	973500	973500	
10	88	Input power - HP	150	170	330	400	760	850	1510	1520	
		Output torque - lb-in	97400	118600	226600	277000	518600	601800	1079700	1097400	
11	78	Input power - HP	130	160	290	370	680	790	1430	1520	
		Output torque - lb-in	97400	119500	226600	293800	518600	623000	114200	1203600	
12	70	Input power - HP	120	140	260	340	580	760	1270	1520	
		Output torque - lb-in	97400	121200	226600	303600	518600	655800	1150500	1345200	
14	63	Input power - HP	110	130	230	310	530	700	1130	1420	
		Output torque - lb-in	97400	122100	226600	308900	518600	676100	1150500	1424900	
16	54.7	Input power - HP	90	120	210	280	470	610	980	1250	
		Output torque - lb-in	97400	123000	226600	311500	518600	685900	1150500	1424900	
18	48.6	Input power - HP	80	100	180	240	430	570	910	1100	
		Output torque - lb-in	95600	123900	226600	312400	518600	700000	1150500	1424900	
20	43.8	Input power - HP	70	90	160	230	390	500	800	1020	
		Output torque - lb-in	97400	123900	226600	313300	518600	700000	1150500	1424900	
22	39.8	Input power - HP	70	80	150	190	350	430	710	890	
		Output torque - lb-in	97400	119500	226600	304400	518600	654900	1150500	1424900	
25	35.0	Input power - HP	60	70	130	170	300	420	630	800	
		Output torque - lb-in	97400	121200	226600	307100	2000	700900	1150500	1424900	
28	31.3	Input power - HP	50	60	110	150	270	380	560	710	
		Output torque - lb-in	97400	122100	226600	308900	518600	700900	1150500	1424900	
32	27.3	Input power - HP	50	60	100	140	240	320	490	620	
		Output torque - lb-in	97400	123000	226600	311500	518600	700000	1150500	1424900	
36	24.3	Input power - HP	40	50	90	120	210	290	450	550	
		Output torque - lb-in	96500	123900	226600	312400	518600	700000	1150500	1424900	
40	21.9	Input power - HP	40	50	80	110	200	260	400	510	
		Output torque - lb-in	97400	123900	226600	313300	518600	700900	1150500	1424900	
45	19.4	Input power - HP	30	40	70	100	170	230	360	450	
		Output torque - lb-in	97400	119500	226600	304400	518600	656700	1150500	1433700	
50	17.5	Input power - HP	30	40	60	90	150	210	320	400	
		Output torque - lb-in	97400	121200	226600	307100	518600	700900	1150500	1433700	
56	15.6	Input power - HP	30	30	60	80	140	190	280	360	
		Output torque - lb-in	97400	122100	226600	308900	518600	700900	1150500	1433700	
63	13.9	Input power - HP	20	30	50	70	120	160	250	320	
		Output torque - lb-in	97400	123900	226600	311500	518600	700900	1150500	1433700	
71	12.3	Input power - HP	20	30	50	60	100	150	230	280	
		Output torque - lb-in	94700	123900	226600	312400	518600	700900	1150500	1433700	
80	10.9	Input power - HP	20	20	40	60	90	130	210	260	
		Output torque - lb-in	95600	123900	226600	313300	518600	700900	1150500	1433700	
90	9.7	Input power - HP	20	20	40	50	80	110	190	240	
		Output torque - lb-in	96500	117700	226600	302700	518600	701800	1150500	1433700	
100	8.8	Input power - HP	10	20	30	40	70	100	170	210	
		Output torque - lb-in	97400	118600	226600	302700	518600	701800	1150500	1433700	
112	7.8	Input power - HP	10	20	30	40	70	90	150	190	
		Output torque - lb-in	97400	120400	226600	303600	518600	701800	1150500	1433700	
125	7.0	Input power - HP	10	10	30	30	60	80	130	160	
		Output torque - lb-in	97400	122100	226600	302700	518600	701800	1150500	1433700	
140	6.3	Input power - HP	10	10	20	30	50	70	120	140	
		Output torque - lb-in	97400	123900	226600	302700	518600	701800	1150500	1433700	
160	5.5	Input power - HP	10	10	20	30	50	60	110	130	
		Output torque - lb-in	97400	123900	226600	303600	518600	701800	1150500	1433700	
180	4.9	Input power - HP	10	10	20	20	40	60	90	120	
		Output torque - lb-in	97400	123900	226600	303600	518600	701800	1150500	1433700	
200	4.4	Input power - HP	10	10	20	20	40	50	80	100	
		Output torque - lb-in	94700	123900	226600	302700	518600	701800	1150500	1433700	
225	3.9	Input power - HP	-	10	-	20	-	50	70	90	
		Output torque - lb-in	-	123900	-	302700	-	701800	1150500	1433700	
250	3.5	Input power - HP	-	10	-	20	-	40	-	80	
		Output torque - lb-in	-	123900	-	303600	-	701800	-	1433700	

# SERIES G

## PARALLEL SHAFT UNIT THERMAL RATINGS

### Thermal Ratings HP

These thermal ratings assume the gear unit is in constant use working in an ambient temperature of 77°F (25°C)\* installed in a large indoor space at sea level.

These ratings must be adjusted for alternative operating and environment conditions refer to Thermal ratings and service factors on page 6. Ratings are for reference purposes. Contact Application Engineering to confirm suitability for your application.

\*maximum bulk oil temperature 203°F (95°C)

### Parallel Shaft Units - Double Reduction

Type of Cooling	Input Speed (rev/min)	Ratio	G1420	G1520	G1620	G1720	G1820	G1920	G2120	G2220	
No Additional Cooling	1750	8:1	110	123	185	176	291	221	263	278	
		16:1	84	98	153	149	241	218	236	252	
	1450	8:1	109	121	191	182	306	246	314	332	
		16:1	84	98	159	156	256	244	285	304	
	1160	8:1	109	120	195	188	320	269	357	377	
		16:1	85	97	164	162	270	266	327	348	
	960	8:1	108	119	199	192	328	283	385	406	
		16:1	85	97	168	166	278	280	353	376	
	Fan Cooling	1750	8:1	198	202	320	309	501	467	556	588
			16:1	162	170	280	274	432	463	518	552
		1450	8:1	175	179	292	280	453	424	520	550
			16:1	142	150	253	247	390	421	484	516
1160		8:1	153	157	264	251	406	383	486	514	
		16:1	123	131	227	221	348	380	451	481	
960		8:1	137	142	244	231	374	354	462	488	
		16:1	110	118	209	202	320	352	427	456	
Cooling Coil		1750	8:1	300	319	498	507	876	748	783	821
			16:1	256	281	451	466	789	744	741	782
		1450	8:1	294	312	498	505	873	750	804	842
			16:1	252	276	451	464	788	746	762	804
	1160	8:1	289	307	498	502	871	752	823	863	
		16:1	248	271	451	463	786	748	781	824	
	960	8:1	285	303	497	501	869	754	835	877	
		16:1	245	268	451	462	786	750	794	838	
	Fan and Cooling Coil	1750	8:1	355	366	578	582	1000	889	956	1002
			16:1	309	326	528	539	908	885	911	961
		1450	8:1	335	347	557	559	960	854	928	974
			16:1	291	309	508	518	872	849	884	934
1160		8:1	315	329	537	537	923	819	901	946	
		16:1	273	293	489	498	837	815	858	907	
960		8:1	302	317	523	523	897	796	883	927	
		16:1	261	281	476	483	813	792	840	888	

### Parallel Shaft Units - Triple Reduction

Type of Cooling	Input Speed (rev/min)	Ratio	G1430	G1530	G1630	G1730	G1830	G1930	G2130	G2230	
No Additional Cooling	1750	22:1	78	83	123	119	197	169	183	194	
		56:1	52	60	91	93	146	130	155	167	
	1450	22:1	75	81	124	122	202	186	215	228	
		56:1	52	59	92	96	153	147	185	199	
	1160	22:1	73	78	124	124	208	200	242	256	
		56:1	52	58	94	99	160	161	211	226	
	960	22:1	72	77	124	126	211	209	259	274	
		56:1	51	58	95	101	164	170	228	244	
	Fan Cooling	1750	22:1	-	-	238	242	411	444	514	537
			56:1	-	-	191	204	334	378	471	497
		1450	22:1	-	-	211	216	365	397	471	493
			56:1	-	-	169	181	295	336	430	454
1160		22:1	-	-	186	190	320	351	428	448	
		56:1	-	-	147	159	257	296	389	411	
960		22:1	-	-	168	173	289	319	397	417	
		56:1	-	-	132	143	231	268	360	381	
Cooling Coil		1750	22:1	210	219	336	344	578	574	534	562
			56:1	166	182	283	301	489	502	491	521
		1450	22:1	203	212	331	340	570	571	545	573
			56:1	161	177	280	298	484	501	502	532
	1160	22:1	197	206	326	336	563	569	555	584	
		56:1	157	172	276	295	479	501	512	543	
	960	22:1	193	202	323	333	558	568	561	591	
		56:1	155	169	274	293	476	500	519	551	

### Parallel Shafts - Quadruple Reduction

Type of Cooling	Input Speed (rev/min)	Ratio	G1440	G1540	G1640	G1740	G1840	G1940	G2140	G2240
No Additional Cooling	1750	100:1	48	56	84	87	138	137	156	173
		200:1	35	40	61	68	108	109	123	139
	1450	100:1	47	54	84	88	142	146	180	198
		200:1	35	40	62	70	113	119	147	163
	1160	100:1	46	52	84	88	146	154	200	218
		200:1	35	39	63	71	117	127	166	183
	960	100:1	46	52	84	89	148	158	213	231
		200:1	34	39	63	72	120	132	178	196

## DIMENSIONS HORIZONTAL PARALLEL SHAFTS DOUBLE REDUCTION

DIMENSIONS IN mm

### G 20 H Double Reduction Parallel Shaft Units Horizontal

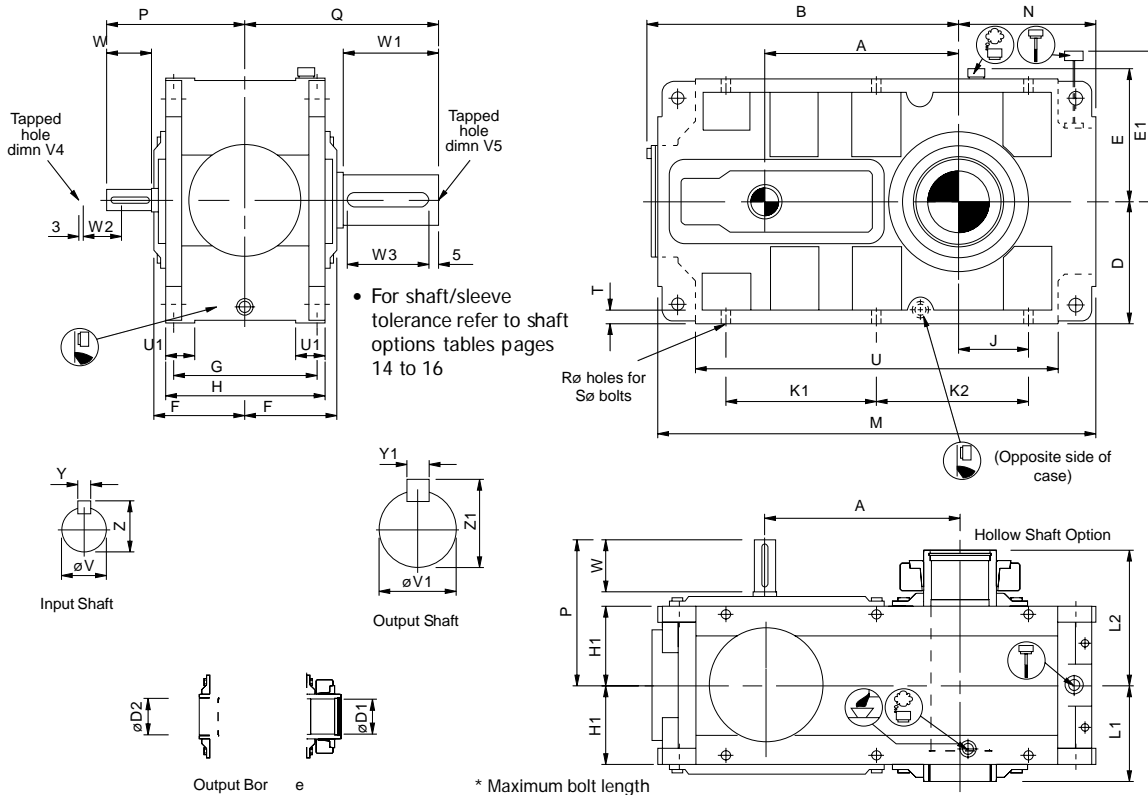

Unit Size	A	B	D	E	E1	F	G	H	H1	J	K1	K2	M	N	P	Q	R	S	T	U	U1
G14	325	554	230	250	370	177	265	300	150	170	285	820	295	315	360	18.5	6 x M16 x 60*	25	684	55	
G15	365	594	230	250	370	177	265	300	150	130	285	820	255	315	370	18.5	6 x M16 x 60*	25	684	55	
G16	430	728	300	335	515	225	330	380	190	225	385	1060	370	370	460	28	6 x M24 x 80*	30	898	70	
G17	485	783	300	335	515	225	330	380	190	170	385	1060	315	370	480	28	6 x M24 x 80*	30	898	70	
G18	570	953	385	420	710	290	440	500	250	153	520	350	1240	338	480	600	33	6 x M30 x 100*	37	1036	90
G19	635	1018	385	420	710	290	440	500	250	220	500	1374	407	480	650	33	6 x M30 x 100*	40	1170	90	
G21	765	1240	465	507	750	340	530	600	300	225	695	480	1655	465	560	700	39	6 x M36 x 100*	50	1380	120
G22	805	1280	465	507	750	340	530	600	300	245	755	490	1715	485	560	730	39	6 x M36 x 100*	50	1440	120

Unit Size	Input Shaft ●						Output Shaft ●						Output Bore ●			
	V	V4	W	W2	Y	Z	V1	V5	W1	W3	Y1	Z1	D1	D2	L1	L2
G14	50 k6	M16 x 36	138	130	14	53.5	110 m6	M30 x63	180	170	28	116	95	100	180	255
G15	50 k6	M16 x 36	138	130	14	53.5	130 m6	M30 x63	190	180	32	137	110	115	180	260
G16	60 m6	M20 x 43	148	140	18	64	145 m6	M42 x81	230	220	36	153	125	130	230	325
G17	60 m6	M20 x 43	148	140	18	64	170 m6	M42 x81	250	240	40	179	145	150	230	340
G18	85 m6	M24 x 52	190	180	22	90	190 m6	M42 x81	300	290	45	200	160	170	300	410
G19	85 m6	M24 x 52	190	180	22	90	210 m6	M42 x81	350	340	50	221	170	180	300	430
G21	110 m6	M30 x 63	210	200	28	116	220 m6	M42 x81	350	340	50	231	210	220	350	500
G22	110 m6	M30 x 63	210	200	28	116	240 m6	M42 x81	380	340	56	252	230	240	350	515

**DIMENSIONS HORIZONTAL PARALLEL SHAFTS DOUBLE REDUCTION**

DIMENSIONS IN inch

**G 20 H Double Reduction Parallel Shaft Units Horizontal**

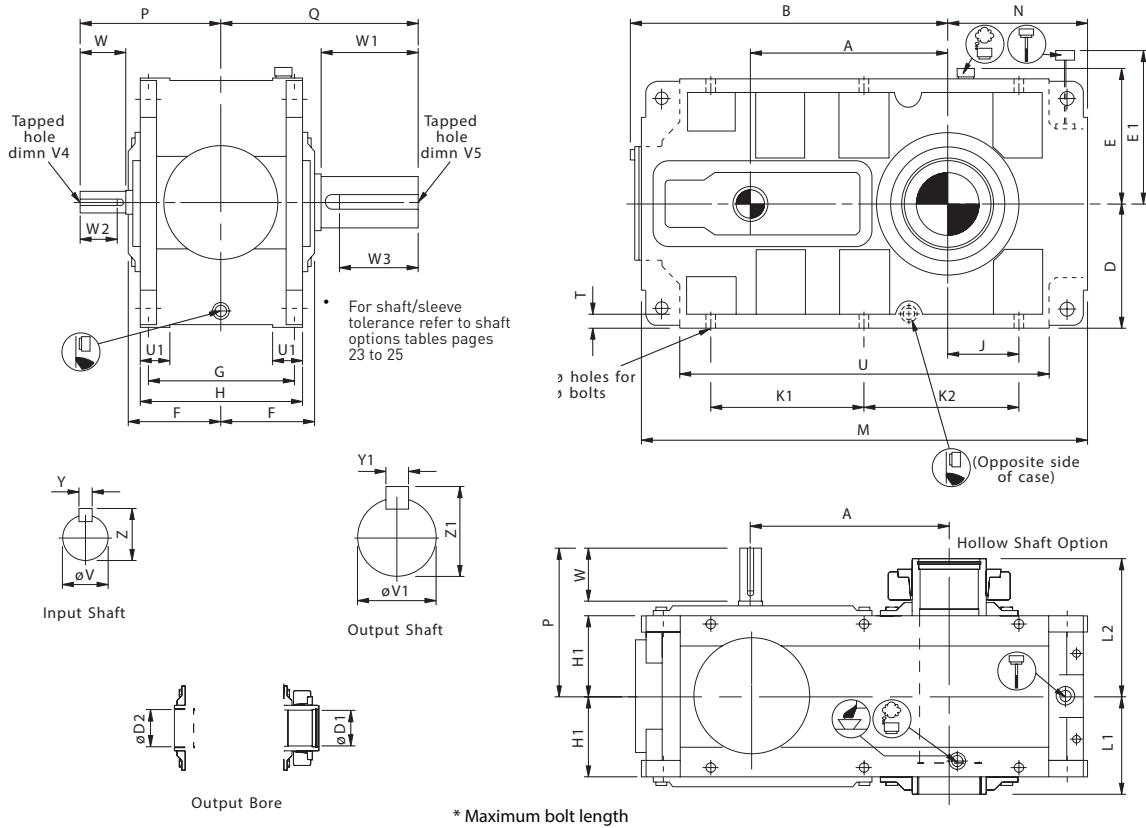

Unit Size	A	B	D	E	E1	F	G	H	H1	J	K1	K2	M	N	P	Q	R	S	T	U	U1
G14	12.80	21.81	9.06	9.84	14.57	6.97	10.43	11.81	5.91	6.69	11.22		32.28	11.61	12.40	14.17	0.73	6 x M16 x 60*	0.98	26.93	2.17
G15	14.37	23.39	9.06	9.84	14.57	6.97	10.43	11.81	5.91	5.12	11.22		32.28	10.04	12.40	14.57	0.73	6 x M16 x 60*	0.98	26.93	2.17
G16	16.93	28.66	11.81	13.19	20.28	8.86	12.99	14.96	7.48	8.86	15.16		41.73	14.57	14.57	18.11	1.10	6 x M24 x 80*	1.18	35.35	2.76
G17	19.09	30.83	11.81	13.19	20.28	8.86	12.99	14.96	7.48	6.69	15.16		41.73	12.40	14.57	18.90	1.10	6 x M24 x 80*	1.18	35.35	2.76
G18	22.44	37.52	15.16	16.54	27.95	11.42	17.32	19.69	9.84	6.02	20.47	13.78	48.82	13.31	18.90	23.62	1.30	6 x M30 x 100*	1.46	40.79	3.54
G19	25.00	40.08	15.16	16.54	27.95	11.42	17.32	19.69	9.84	8.66	19.69		54.09	16.02	18.90	25.59	1.30	6 x M30 x 100*	1.57	46.06	3.54
G21	30.12	48.82	18.31	19.96	29.53	13.39	20.87	23.62	11.81	8.86	27.36	18.90	65.16	18.31	22.05	27.56	1.54	6 x M36 x 100*	1.97	54.33	4.72
G22	31.69	50.39	18.31	19.96	29.53	13.39	20.87	23.62	11.81	9.45	28.94	19.49	67.52	19.09	22.05	28.74	1.54	6 x M36 x 100*	1.97	56.69	4.72

Unit Size	Input Shaft						Output Shaft						Output Bore			
	V	V4	W	W2	Y	Z	V1	V5	W1	W3	Y1	Z1	D1	D2	L1	L2
G14	1.875	5/8 UNF x 1.25	5.31	4.13	0.500	2.10	4.500	1 UNF x 2	7.09	6.50	1.00	4.94	3.74	3.94	7.09	10.04
G15	1.875	5/8 UNF x 1.25	5.31	4.13	0.500	2.10	5.000	1 UNF x 2	7.48	7.13	1.25	5.55	4.33	4.53	7.09	10.24
G16	2.250	3/4 UNF x 1.62	5.71	4.13	0.500	2.47	6.000	1.25 UNF x 2.5	9.06	8.75	1.50	6.66	4.92	5.12	9.06	12.80
G17	2.250	3/4 UNF x 1.62	5.71	4.13	0.500	2.47	6.750	1.25 UNF x 2.5	9.84	9.38	1.75	7.39	5.71	5.91	9.06	13.39
G18	3.250	1 UNF x 2	7.48	5.88	0.750	3.58	7.500	1.5 UNF x 3	11.81	11.38	1.75	8.15	6.30	6.69	11.81	16.14
G19	3.250	1 UNF x 2	7.48	5.88	0.750	3.58	8.250	1.5 UNF x 3	13.78	13.00	2.00	8.88	6.69	7.09	11.81	16.93
G21	4.250	1 UNF x 2	8.27	7.50	1.000	4.69	8.500	1.5 UNF x 3	13.78	13.00	2.00	9.13	8.27	8.66	13.78	19.69
G22	4.250	1 UNF x 2	8.27	7.5	1.000	4.69	9.250	1.5 UNF x 3	14.96	14.25	2.50	9.95	9.06	9.45	13.78	20.28

## DIMENSIONS VERTICAL PARALLEL SHAFTS DOUBLE REDUCTION

DIMENSIONS IN mm

### G 20 H Double Reduction Parallel Shaft Units Vertical

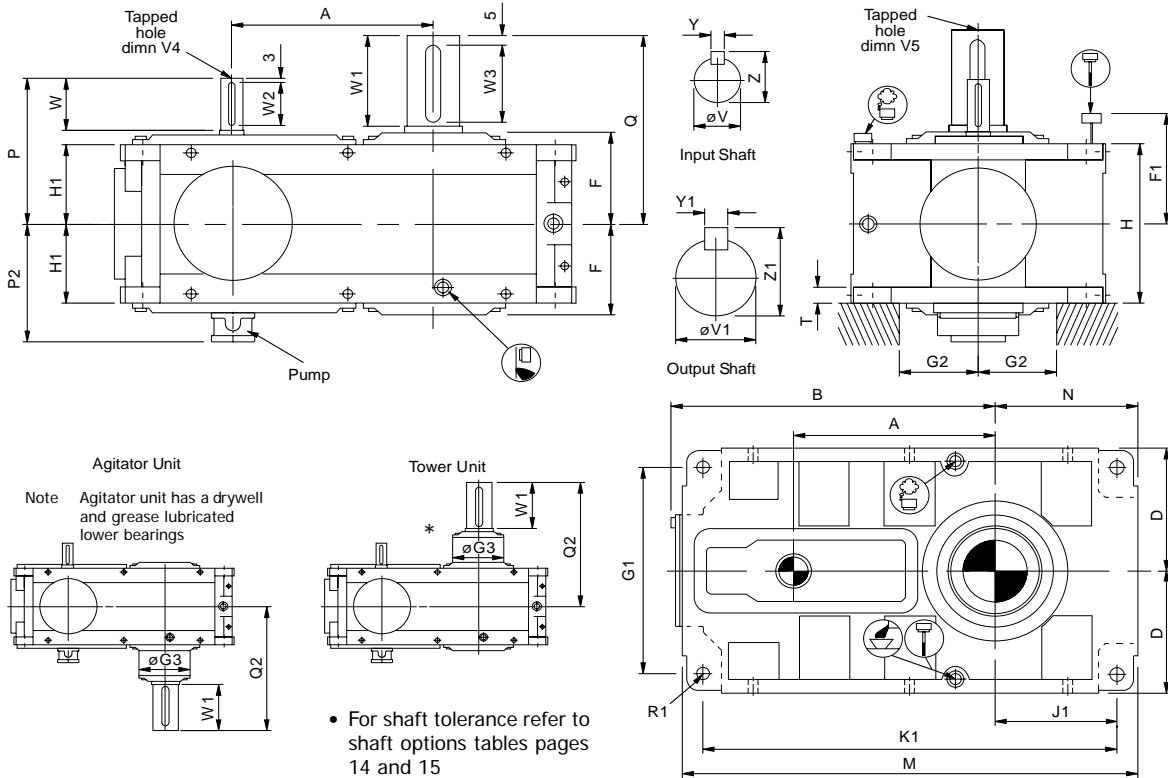

Unit Size	A	B	D	F	F1	G1	G2 (min)	G3	H	H1	J1	K1	M	N	P	P2	Q	Q2	R1	T
G14	325	554	230	177	390	390	135	230	300	150	260	750	820	295	315	236	360	475	4 X $\phi$ 24	30
G15	365	594	230	177	390	390	135	260	300	150	220	750	820	255	315	236	370	495	4 X $\phi$ 24	30
G16	430	728	300	225	515	506	175	300	380	190	325	970	1060	370	370	285	460	595	4 X $\phi$ 33	45
G17	485	783	300	225	515	506	175	340	380	190	270	970	1060	315	370	285	480	615	4 X $\phi$ 33	45
G18	570	953	385	290	700	656	205	370	500	250	281	1126	1240	338	480	345	600	760	4 X $\phi$ 40	55
G19	635	1018	385	290	700	656	205	400	500	250	350	1260	1374	407	480	345	650	815	4 X $\phi$ 40	55
G21	765	1240	465	340	750	790	255	500	600	300	395	1515	1655	465	560	400	700	925	4 X $\phi$ 48	70
G22	805	1280	465	340	750	790	265	*	600	300	415	1575	1715	485	560	400	730	*	4 X $\phi$ 48	70

Unit Size	Input Shaft •						Output Shaft •					
	V	V4	W	W2	Y	Z	V1	V5	W1	W3	Y1	Z1
G14	50 k6	M16 x 36	138	130	14	53.5	110 m6	M30 x63	180	170	28	116
G15	50 k6	M16 x 36	138	130	14	53.5	130 m6	M30 x63	190	180	32	137
G16	60 m6	M20 x 43	148	140	18	64	145 m6	M42 x81	230	220	36	153
G17	60 m6	M20 x 43	148	140	18	64	170 m6	M42 x81	250	240	40	179
G18	85 m6	M24 x 52	190	180	22	90	190 m6	M42 x81	300	290	45	200
G19	85 m6	M24 x 52	190	180	22	90	210 m6	M42 x81	350	340	50	221
G21	110 m6	M30 x 63	210	200	28	116	220 m6	M42 x81	350	340	50	231
G22	110 m6	M30 x 63	210	200	28	116	240 m6	M42 x81	380	340	56	252

\* = Contact Application Engineering



DIMENSIONS IN mm

## DIMENSIONS HORIZONTAL PARALLEL SHAFTS TRIPLE & QUADRUPLE REDUCTION

**G** **3** **0** **H** Triple and Quadruple Reduction Parallel Shaft Units Horizontal

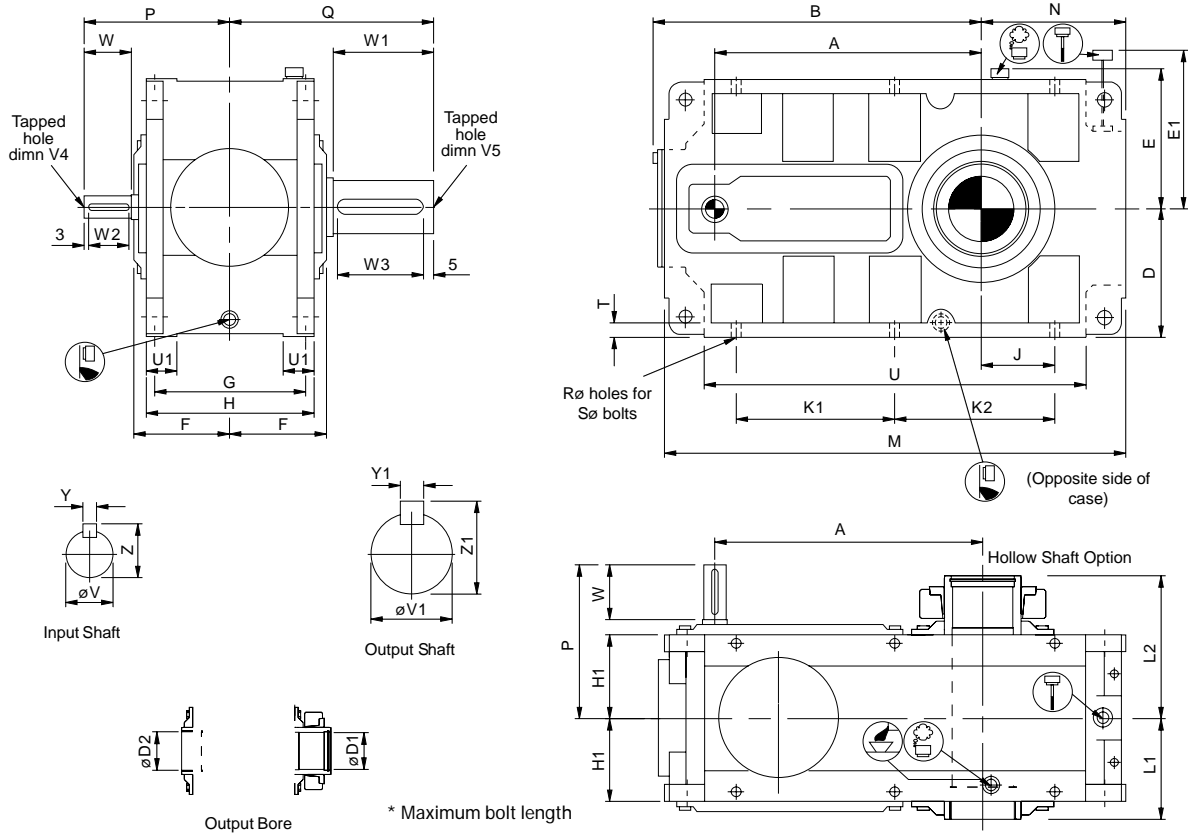

Unit Size	A	B	D	E	E1	F	G	H	H1	J	K1	K2	M	N	P	Q	R	S	T	U	U1
G14	435	554	230	250	370	177	265	300	150	170	285		820	295	275	360	18.5	6 X m16 X 60*	25	684	55
G15	475	594	230	250	370	177	265	300	150	130	285		820	255	275	370	18.5	6 X m16 X 60*	25	684	55
G16	570	728	300	335	515	225	330	380	190	225	385		1060	370	340	460	28	6 X m24 X 80*	30	898	70
G17	625	783	300	335	515	225	330	380	190	170	385		1060	315	340	480	28	6 X m24 X 80*	30	898	70
G18	755	953	385	420	710	290	440	500	250	153	520	350	1240	338	440	600	33	6 X m30 X 100*	37	1036	90
G19	820	1018	385	420	710	290	440	500	250	220	500		1374	407	440	650	33	6 X m30 X 100*	40	1170	90
G21	1010	1240	465	507	750	340	530	600	300	225	695	480	1655	465	540	700	39	6 X m36 X 100*	50	1380	120
G22	1050	1280	465	507	750	340	530	600	300	245	745	490	1715	485	540	730	39	6 X m36 X 100*	50	1440	120

Unit Size	Input Shaft ●						Output Shaft ●						Output Bore ●			
	V	V4	W	W2	Y	Z	V1	V5	W1	W3	Y1	Z1	D1	D2	L1	L2
G14	35 k6	M12 x 25	99	90	10	38	110 m6	M30 x63	180	170	28	116	95	100	180	255
G15	35 k6	M12 x 25	99	90	10	38	130 m6	M30 x63	190	180	32	137	110	115	180	260
G16	45 k6	M16 x 36	118	110	14	48.5	145 m6	M42 x81	230	220	36	153	125	130	230	325
G17	45 k6	M16 x 36	118	110	14	48.5	170 m6	M42 x81	250	240	40	179	145	150	230	340
G18	60 m6	M20 x 43	150	140	18	64	190 m6	M42 x81	300	290	45	200	160	170	300	410
G19	60 m6	M20 x 43	150	140	18	64	210 m6	M42 x81	350	340	50	221	170	180	300	430
G21	80 m6	M20 x 43	190	180	22	85	220 m6	M42 x81	350	340	50	231	210	220	350	500
G22	80 m6	M20 x 43	190	180	22	85	240 m6	M42 x81	380	340	56	252	230	240	350	515

DIMENSIONS IN inch

**DIMENSIONS HORIZONTAL PARALLEL SHAFTS TRIPLE & QUADRUPLE REDUCTION**

**G** **3** **4** **0** **H** Triple and Quadruple Reduction Parallel Shaft Units Horizontal

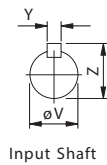
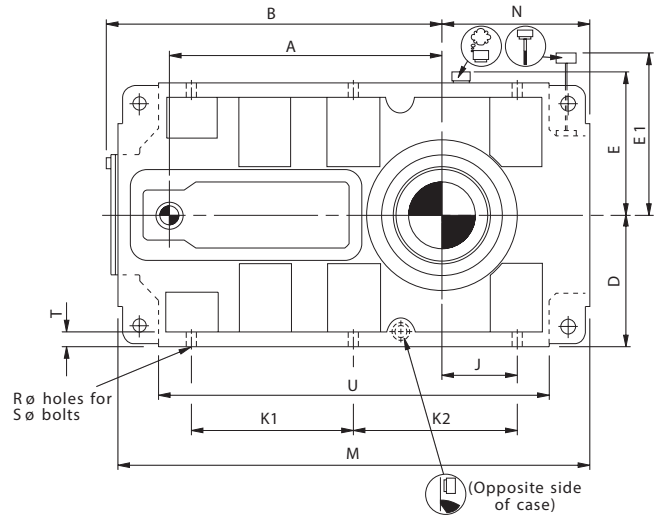
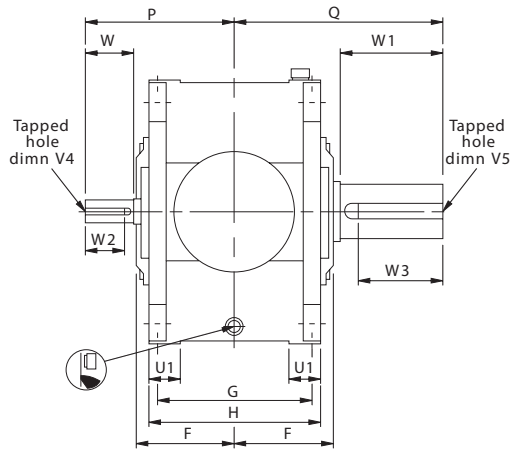

Input Shaft

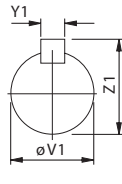

Output Shaft



Output Bore



\* Maximum bolt length

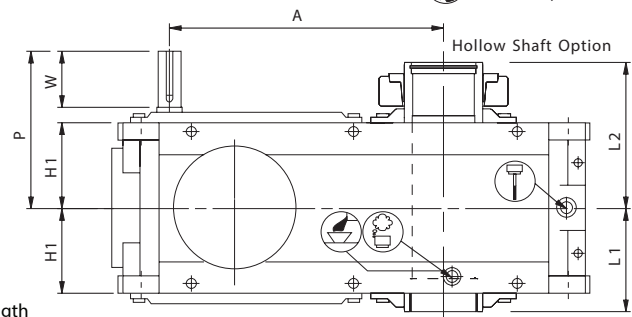

Unit Size	A	B	D	E	E1	F	G	H	H1	J	K1	K2	M	N	P	Q	R	S	T	U	U1
G14	17.13	21.81	9.06	9.84	14.57	6.97	10.43	11.81	5.91	6.69	11.22	32.28	11.61	10.83	14.17	0.73	6 X m16 X 60*	0.98	26.93	2.17	
G15	18.70	23.39	9.06	9.84	14.57	6.97	10.43	11.81	5.91	5.12	11.22	32.28	10.04	10.83	14.57	0.73	6 X m16 X 60*	0.98	26.93	2.17	
G16	22.44	28.66	11.81	13.19	20.28	8.86	12.99	14.96	7.48	8.86	15.16	41.73	14.57	13.39	18.11	1.10	6 X m24 X 80*	1.18	35.35	2.76	
G17	24.61	30.83	11.81	13.19	20.28	8.86	12.99	14.96	7.48	6.69	15.16	41.73	12.40	13.39	18.90	1.10	6 X m24 X 80*	1.18	35.35	2.76	
G18	29.72	37.52	15.16	16.54	27.95	11.42	17.32	19.69	9.84	6.02	20.47	13.78	48.82	13.31	17.32	23.62	1.30	6 X m30 X 100*	1.46	40.79	3.54
G19	32.28	40.08	15.16	16.54	27.95	11.42	17.32	19.69	9.84	8.66	19.69	54.09	16.02	17.32	25.59	1.30	6 X m30 X 100*	1.57	46.06	3.54	
G21	39.76	48.82	18.31	19.96	29.53	13.39	20.87	23.62	11.81	8.86	27.36	18.90	65.16	18.31	21.26	27.56	1.54	6 X m36 X 100*	1.97	54.33	4.72
G22	41.34	50.39	18.31	19.96	29.53	13.39	20.87	23.62	11.81	9.45	28.94	19.49	67.52	19.09	21.26	28.74	1.54	6 X m36 X 100*	1.97	56.69	4.72

Unit Size	Input Shaft						Output Shaft						Output Bore			
	V	V4	W	W2	Y	Z	V1	V5	W1	W3	Y1	Z1	D1	D2	L1	L2
G14	1.375	1/2 UNF x 1	3.74	3.00	0.313	1.51	4.500	1 UNF x 2	7.09	6.50	1.00	4.94	3.74	3.94	7.09	10.04
G15	1.375	1/2 UNF x 1	3.74	3.00	0.313	1.51	5.000	1 UNF x 2	7.48	7.13	1.25	5.55	4.33	4.53	7.09	10.24
G16	1.750	5/8 UNF x 1.25	4.53	4.13	0.375	1.92	6.000	1.25 UNF x 2.5	9.06	8.75	1.50	6.66	4.92	5.12	9.06	12.80
G17	1.750	5/8 UNF x 1.25	4.53	4.13	0.375	1.92	6.750	1.25 UNF x 2.5	9.84	9.38	1.75	7.39	5.71	5.91	9.06	13.39
G18	2.250	3/4 UNF x 1.62	5.71	4.13	0.500	2.47	7.500	1.5 UNF x 3	11.81	11.38	1.75	8.15	6.30	6.69	11.81	16.14
G19	2.250	3/4 UNF x 1.62	5.71	4.13	0.500	2.47	8.250	1.5 UNF x 3	13.78	13.00	2.00	8.88	6.69	7.09	11.81	16.93
G21	3.000	3/4 UNF x 1.62	7.48	6.50	0.750	3.33	8.500	1.5 UNF x 3	13.78	13.00	2.00	9.13	8.27	8.66	13.78	19.69
G22	3.000	3/4 UNF x 1.62	7.48	6.50	0.750	3.33	9.250	1.5 UNF x 3	14.26	14.25	2.50	9.95	9.06	9.45	13.78	20.28

## DIMENSIONS VERTICAL PARALLEL SHAFTS TRIPLE & QUADRUPLE REDUCTION

DIMENSIONS IN mm



Triple and Quadruple Reduction Parallel Shaft Units Vertical

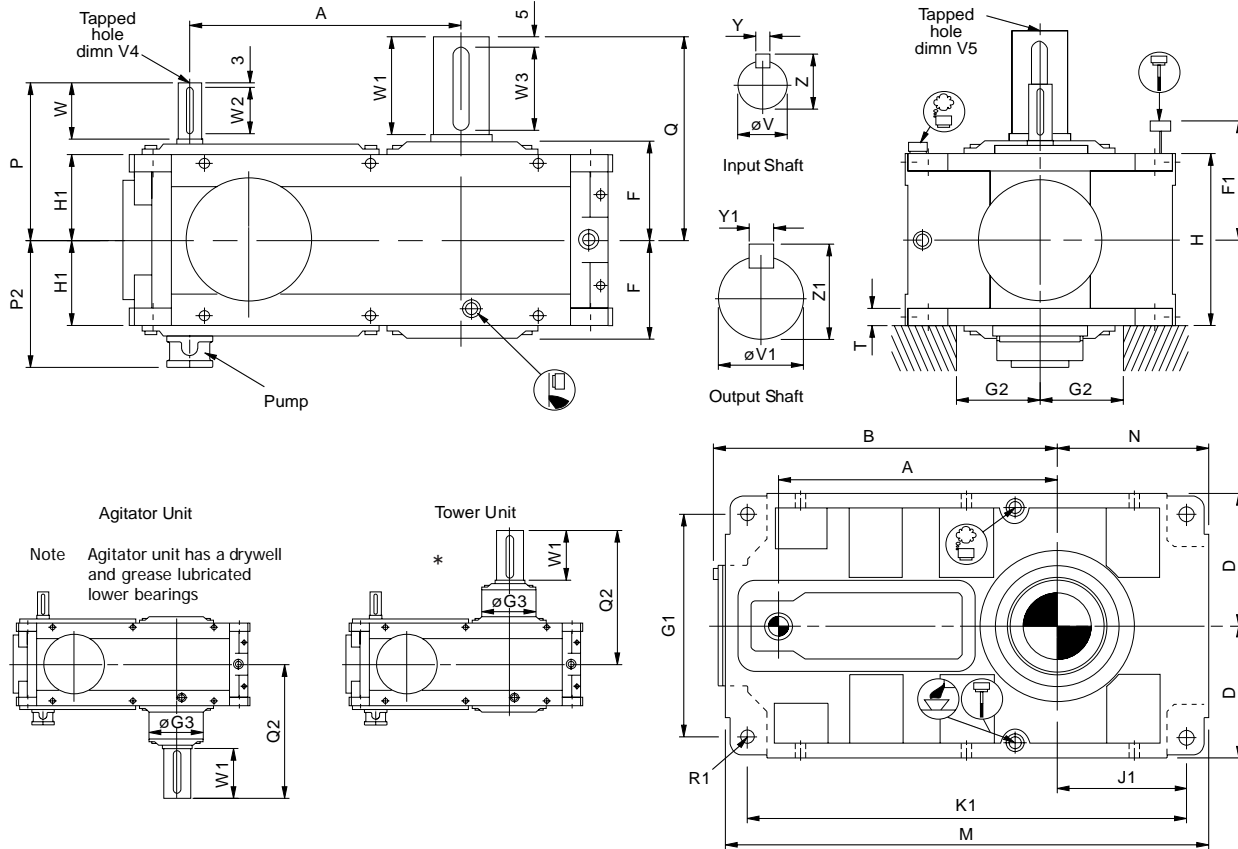

Unit Size	A	B	D	F	F1	G1	G2 min	G3	H	H1	J1	K1	M	N	P	P2	Q	Q2	R1	T
G14	435	554	230	177	390	390	135	230	300	150	260	750	820	295	275	236	360	475	4 X Ø 24	30
G15	475	594	230	177	390	390	135	260	300	150	220	750	820	255	275	236	370	495	4 X Ø 24	30
G16	570	728	300	225	515	506	175	300	380	190	325	970	1060	370	340	285	460	595	4 X Ø 33	45
G17	625	783	300	225	515	506	175	340	380	190	270	970	1060	315	340	285	480	615	4 X Ø 33	45
G18	755	953	385	290	700	656	205	370	500	250	281	1126	1240	338	440	345	600	760	4 X Ø 40	55
G19	820	1018	385	290	700	656	205	400	500	250	350	1260	1374	407	440	345	650	815	4 X Ø 40	55
G21	1010	1240	465	340	750	790	255	500	600	300	395	1515	1655	465	540	400	700	925	4 X Ø 48	70
G22	1050	1280	465	340	750	790	265	*	600	300	415	1575	1715	485	540	400	730	*	4 X Ø 48	70

Unit Size	Input Shaft ●						Output Shaft ●					
	V	V4	W	W2	Y	Z	V1	V5	W1	W3	Y1	Z1
G14	35 k6	M12 x 25	99	90	10	38	110 m6	M30 x 63	180	170	28	116
G15	35 k6	M12 x 25	99	90	10	38	130 m6	M30 x 63	190	180	32	137
G16	45 k6	M16 x 36	118	110	14	48.5	145 m6	M42 x 81	230	220	36	153
G17	45 k6	M16 x 36	118	110	14	48.5	170 m6	M42 x 81	250	240	40	179
G18	60 m6	M20 x 43	150	140	18	64	190 m6	M42 x 81	300	290	45	200
G19	60 m6	M20 x 43	150	140	18	64	210 m6	M42 x 81	350	340	50	221
G21	80 m6	M20 x 43	190	180	22	85	220 m6	M42 x 81	350	340	50	231
G22	80 m6	M20 x 43	190	180	22	85	240 m6	M42 x 81	380	340	56	252

\* = Contact Application Engineering

DIMENSIONS IN inch

**DIMENSIONS VERTICAL PARALLEL SHAFTS TRIPLE & QUADRUPLE REDUCTION**

**G** 3 0 V Triple and Quadruple Reduction Parallel Shaft Units Vertical

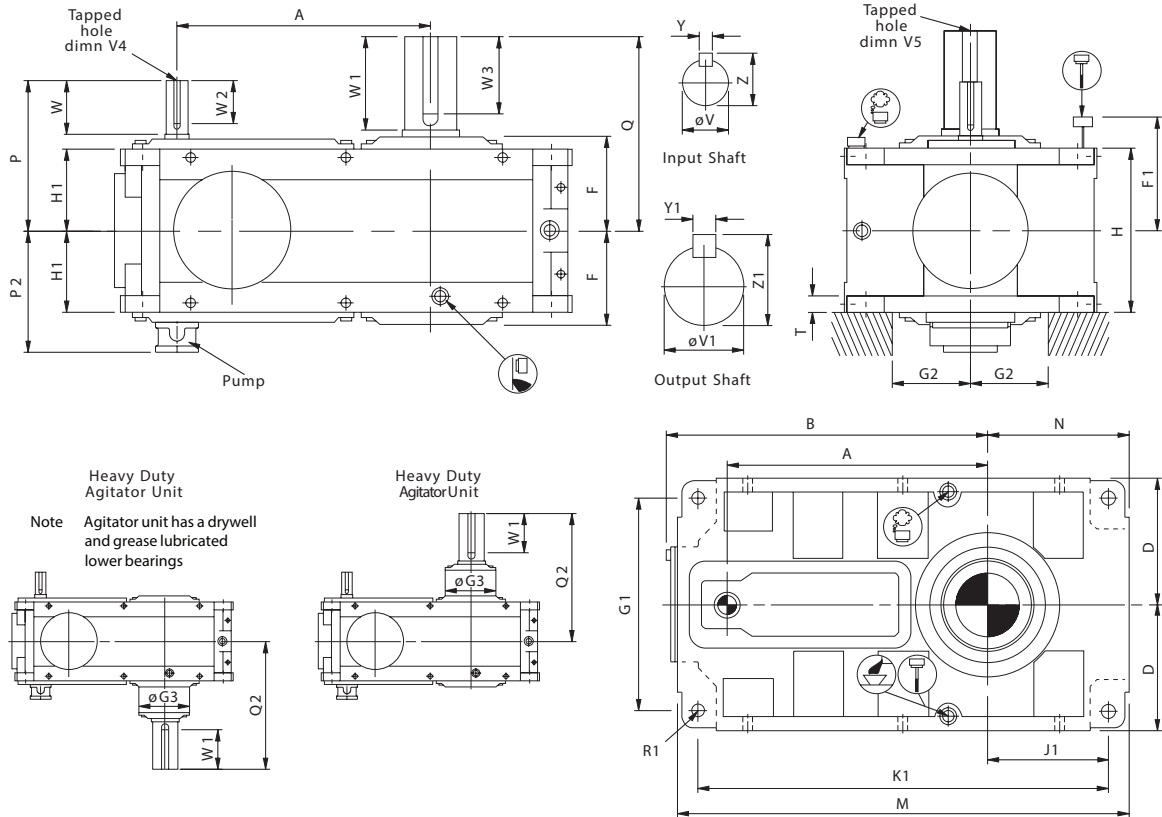

Unit Size	A	B	D	F	F1	G1	G2 min	G3	H	H1	J1	K1	M	N	P	P2	Q	Q2	R1	T
G14	17.13	21.81	9.06	6.97	15.35	15.35	5.31	9.06	11.81	5.91	10.24	29.53	32.28	11.61	10.83	9.29	14.17	18.70	4 X $\phi$ 24	1.18
G15	18.70	23.39	9.06	6.97	15.35	15.35	5.31	10.24	11.81	5.91	8.66	29.53	32.28	10.04	10.83	9.29	14.57	19.49	4 X $\phi$ 24	1.18
G16	22.44	28.66	11.81	8.86	20.28	19.92	6.89	11.81	14.96	7.48	12.80	38.19	41.73	14.57	13.39	11.22	18.11	23.43	4 X $\phi$ 33	1.77
G17	24.61	30.83	11.81	8.86	20.28	19.92	6.89	13.39	14.96	7.48	10.63	38.19	41.73	12.40	13.39	11.22	18.90	24.21	4 X $\phi$ 33	1.77
G18	29.72	37.52	15.16	11.42	27.56	25.83	8.07	14.57	19.69	9.84	11.06	44.33	48.82	13.31	17.32	13.58	23.62	29.92	4 X $\phi$ 40	2.17
G19	32.28	40.08	15.16	11.42	27.56	25.83	8.07	15.75	19.69	9.84	13.78	49.61	54.09	16.02	17.32	13.58	25.59	32.09	4 X $\phi$ 40	2.17
G21	39.76	48.82	18.31	13.39	29.53	31.10	10.04	19.69	23.62	11.81	15.55	59.65	65.16	18.31	21.26	15.75	27.56	36.42	4 X $\phi$ 48	2.76
G22	41.34	50.39	18.31	13.39	29.53	31.10	10.43	*	23.62	11.81	16.34	62.01	67.52	19.09	21.26	15.75	28.74	*	4 X $\phi$ 48	2.76

Unit Size	Input Shaft						Output Shaft					
	V	V4	W	W2	Y	Z	V1	V5	W1	W3	Y1	Z1
G14	1.375	5/8 UNF x 1.25	5.31	4.13	0.500	2.10	4.500	1 UNF x 2	7.09	6.50	1.00	4.94
G15	1.375	5/8 UNF x 1.25	5.31	4.13	0.500	2.10	5.000	1 UNF x 2	7.48	7.13	1.25	5.55
G16	1.750	3/4 UNF x 1.62	5.71	4.13	0.500	2.47	6.000	1.25 UNF x 2.5	9.06	8.75	1.50	6.66
G17	1.750	3/4 UNF x 1.62	5.71	4.13	0.500	2.47	6.750	1.25 UNF x 2.5	9.84	9.38	1.75	7.39
G18	2.250	1 UNF x 2	7.48	5.88	0.750	3.58	7.500	1.5 UNF x 3	11.81	11.38	1.75	8.15
G19	2.250	1 UNF x 2	7.48	5.88	0.750	3.58	8.250	1.5 UNF x 3	13.78	13.00	2.00	8.88
G21	3.000	1 UNF x 2	8.27	7.50	1.000	4.69	8.500	1.5 UNF x 3	13.78	13.00	2.00	9.13
G22	3.000	1 UNF x 2	8.27	7.50	1.000	4.69	9.250	1.5 UNF x 3	14.96	14.25	2.50	9.95

# SERIES G

## FAN COOLING DIMENSIONS PARALLEL SHAFTS

### Parallel Shaft Units with Mechanical Fans

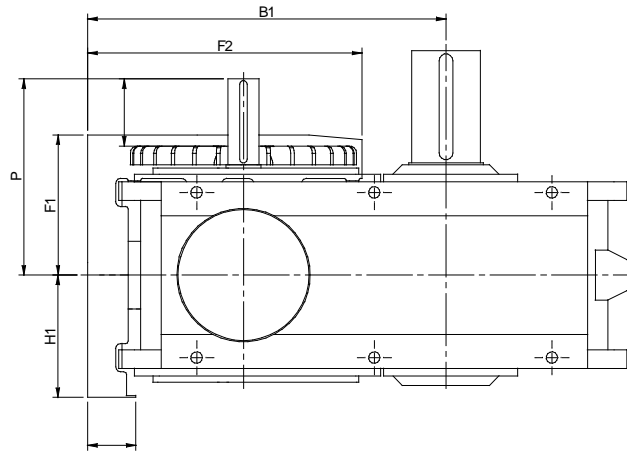
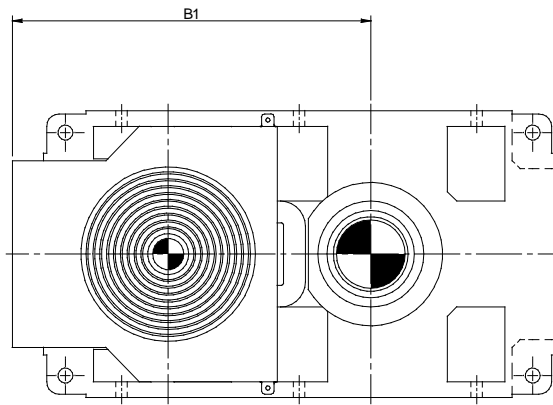

#### Double Reduction

Unit Size	B1	F1	F2	H1	H2	P	W3 (Useable shaft extension)
G14	23.03	8.86	17.80	7.87	2.48	12.40	4.25
G15	24.61	8.86	17.80	7.87	2.48	12.40	4.25
G16	30.16	11.06	22.87	9.65	3.35	14.57	4.25
G17	32.32	11.06	22.87	9.65	3.35	14.57	4.25
G18	39.57	14.21	29.84	11.97	4.33	18.90	5.31
G19	42.13	14.21	29.84	11.97	4.33	18.90	5.31
G21	52.48	16.85	37.83	14.09	6.10	22.05	6.10
G22	54.06	16.85	37.83	14.09	6.10	22.05	6.10

#### Triple and Quadruple Reduction

Unit Size	B1	F1	F2	H1	H2	P	W3 (Useable shaft extension)
G14	Not Available						
G15	Not Available						
G16	30.16	10.55	18.54	9.65	3.35	13.39	3.07
G17	32.32	10.55	18.54	9.65	3.35	13.39	3.07
G18	39.57	13.78	24.53	11.97	4.33	17.32	4.33
G19	42.13	13.78	24.53	11.97	4.33	17.32	4.33
G21	52.48	16.85	31.61	14.09	6.10	21.26	5.31
G22	54.06	16.85	31.61	14.09	6.10	21.26	5.31

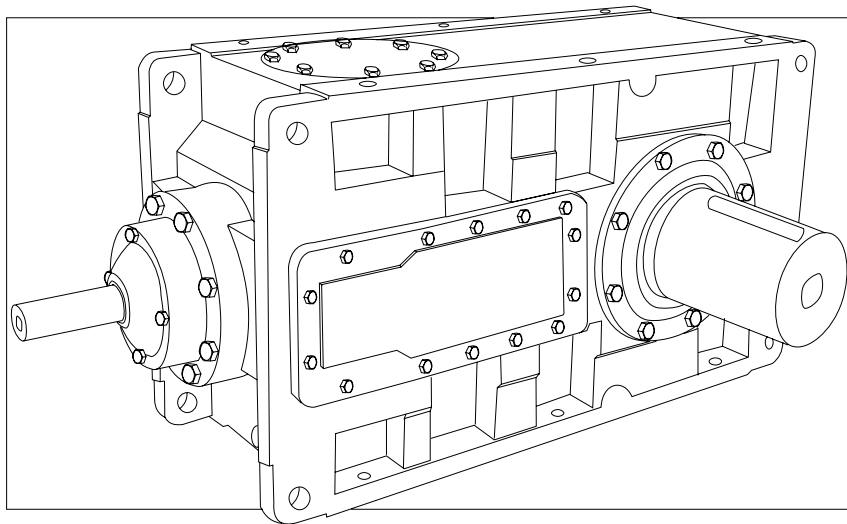

G

## RIGHT ANGLE UNITS



# SERIES G

## MOMENTS OF INERTIA RIGHT ANGLE SHAFTS

### MOMENTS OF INERTIA (lb - in<sup>2</sup>) Referred to Input Shaft

#### RIGHT ANGLE UNITS - without fans

NOMINAL RATIO COLUMN ENTRY [6   7   8]	RIGHT ANGLE SHAFT UNITS - SIZE								
	G14	G15	G16	G17	G18	G19	G21	G22	
8.0	209	-	718	-	-	-	-	-	TRIPLE REDUCTION
9.0	193	-	705	-	-	10671	-	-	
10.	185	-	664	-	-	9918	10808	10808	
11.	176	-	626	-	-	9234	10055	10055	
12.	169	193	595	722	3482	8687	9371	9371	
14.	162	185	568	670	3300	8174	8824	8824	
16.	157	176	540	329	3218	7730	8311	8311	
18.	152	168	518	595	3078	7319	7832	7832	
20.	149	161	515	561	2893	6977	7422	7422	
22.	39	156	294	534	2846	6498	7080	7080	
25.	38	150	286	528	2740	2702	6909	6909	
28.	36	41	279	304	677	2589	2760	2760	
32.	34	39	272	294	657	2483	2638	2638	
36.	33	38	267	286	624	2398	2521	2521	
40.	32	36	265	277	580	2326	2428	2428	
45.	17	34	214	270	568	2288	2346	2346	
50.	15	32	210	268	544	1040	2305	2305	
56.	15	17	209	215	284	1006	1053	1053	
63.	14	15	207	212	265	978	1019	1019	
71.	-	15	149	210	260	964	988	988	
80.	-	14	149	209	250	2565	971	971	
90.	-	-	38	150	523	2538	2712	2712	
100	-	-	36	149	516	551	2702	2702	
112	-	-	36	38	287	540	612	612	
125	-	-	32	37	286	537	602	602	
140	-	-	32	36	282	499	599	599	
160	-	-	32	33	268	496	537	537	
180	-	-	16	32	267	493	530	530	
200	-	-	14	32	265	248	528	528	
225	-	-	14	16	215	233	274	274	
250	-	-	14	14	209	229	246	246	
280	-	-	-	14	209	229	245	245	
315	-	-	-	14	209	-	243	243	

#### RIGHT ANGLE UNITS - with fans

If fan cooling is required the inertia of the fan must be added to the table above.

#### MOMENTS OF INERTIA of fans (lb - in<sup>2</sup>)

	G14/G15	G16/G17	G18/G19	G21
TRIPLE REDUCTION	33	86	276	573

$GD^2 \text{ (lb in}^2\text{)} = 4 \times \text{Moment of Inertia (lb - in}^2\text{)}$



# SERIES G

## EXACT RATIOS RIGHT ANGLE SHAFTS

### EXACT RATIOS - RIGHT ANGLE UNITS

#### Triple Reduction

Nominal Ratio Column Entry 6   7   8	RIGHT ANGLE SHAFT UNITS - SIZE							
	G14	G15	G16	G17	G18	G19	G21	G22
8.0	7.691	-	8.095	-	7.842	-	-	-
9.0	8.863	-	8.755	-	8.663	-	9.127	-
10.	9.774	-	9.584	-	9.939	-	10.11	10.194
11.	10.816	-	10.937	-	11.08	-	11.434	11.291
12.	12.018	12.338	12.312	12.323	12.109	12.464	12.529	12.77
14.	13.42	13.653	13.718	14.062	13.586	13.893	14.041	13.993
16.	15.077	15.17	15.675	15.83	15.868	15.184	15.828	15.682
18.	17.065	16.94	17.807	17.637	17.474	17.037	17.973	17.678
20.	19.495	19.031	19.225	20.154	19.817	19.898	20.594	20.073
22.	21.775	21.541	21.756	22.894	22.636	21.912	22.136	23.001
25.	24.195	24.609	24.492	24.718	24.738	24.85	25.597	24.723
28.	27.017	27.487	27.288	27.972	27.757	28.384	28.686	28.589
32.	30.353	30.541	31.182	31.49	32.419	31.021	32.337	32.039
36.	34.356	34.104	35.422	35.084	35.7	34.806	36.718	36.117
40.	39.249	38.315	38.243	40.091	40.487	40.652	42.073	41.01
45.	41.605	43.368	43.244	45.543	42.83	44.767	45.223	46.991
50.	46.743	49.544	49.417	49.17	50.024	50.769	52.335	50.509
56.	52.907	52.518	56.136	55.6	55.087	53.708	59.426	58.452
63.	60.442	59.003	60.606	63.536	62.474	62.729	68.092	66.372
71.	-	66.784	-	72.174	-	69.078	73.19	76.051
80.	-	76.295	-	77.922	-	78.34	-	81.745

#### Quadruple Reduction

Nominal Ratio Column Entry 6   7   8	RIGHT ANGLE SHAFT UNITS - SIZE							
	G14	G15	G16	G17	G18	G19	G21	G22
71.	-	-	73.432	-	68.805	-	-	-
80.	-	-	79.28	-	78.03	-	83.586	-
90.	-	-	89.584	94.412	88.634	86.279	89.844	93.356
100	-	-	101.765	101.931	97.661	97.847	102.173	100.345
112	-	-	109.869	115.18	110.755	111.207	117.073	114.115
125	-	-	130.142	130.84	124.29	122.463	125.838	130.757
140	-	-	147.837	141.26	136.87	138.883	149.034	140.546
160	-	-	159.611	167.326	155.221	155.855	170.768	166.453
180	-	-	169.192	190.077	175.521	171.63	183.552	190.728
200	-	-	200.412	205.214	196.97	194.643	194.176	205.007
225	-	-	227.661	217.533	216.906	220.098	229.968	216.872
250	-	-	245.792	257.672	245.99	246.994	263.505	256.847
280	-	-	-	292.708	-	271.994	283.223	294.304
315	-	-	-	316.018	-	308.463	-	316.338

# SERIES G

## RIGHT ANGLE SHAFT MECHANICAL RATINGS AT 1750 RPM INPUT

Nominal Ratio Column Entry	Nominal Output Speed RPM	Mechanical Capacity	RIGHT ANGLE SHAFT UNITS - SIZE								
			G14	G15	G16	G17	G18	G19	G21	G22	
8.0	219	Input power - HP	260	-	560	-	<b>1240</b>	-	-	-	
		Output torque -lb-in	70100	-	157500	-	<b>341600</b>	-	-	-	
9.0	194	Input power - HP	260	-	560	-	<b>1240</b>	-	<b>2450</b>	-	
		Output torque -lb-in	80800	-	170800	-	<b>377000</b>	-	<b>783200</b>	-	
10	175	Input power - HP	260	-	560	-	<b>1240</b>	-	<b>2450</b>	<b>2450</b>	
		Output torque -lb-in	89400	-	186700	-	<b>432800</b>	-	<b>867300</b>	<b>878800</b>	
11	156	Input power - HP	250	-	560	-	<b>1240</b>	-	<b>2450</b>	<b>2450</b>	
		Output torque -lb-in	95600	-	212400	-	<b>481400</b>	-	<b>982400</b>	<b>973500</b>	
12	140	Input power - HP	230	260	530	560	<b>1220</b>	<b>1240</b>	<b>2430</b>	<b>2450</b>	
		Output torque -lb-in	97400	112400	225700	239800	<b>518600</b>	<b>542500</b>	<b>1062000</b>	<b>1097400</b>	
14	125	Input power - HP	210	250	470	560	<b>1090</b>	<b>1240</b>	<b>2290</b>	<b>2410</b>	
		Output torque -lb-in	97400	120400	225700	273500	<b>518600</b>	<b>603600</b>	<b>1124000</b>	<b>1194800</b>	
16	109	Input power - HP	190	230	420	540	<b>940</b>	<b>1240</b>	<b>2070</b>	<b>2280</b>	
		Output torque -lb-in	97400	121200	225700	298200	<b>518600</b>	<b>659300</b>	<b>1150500</b>	<b>1256700</b>	
18	97	Input power - HP	170	210	370	500	<b>850</b>	<b>1160</b>	<b>1830</b>	<b>2090</b>	
		Output torque -lb-in	97400	122100	226600	308000	<b>518600</b>	<b>688500</b>	<b>1150500</b>	<b>1301000</b>	
20	87.5	Input power - HP	150	190	340	440	<b>750</b>	<b>1010</b>	<b>1600</b>	<b>1890</b>	
		Output torque -lb-in	97400	123900	226600	304400	<b>518600</b>	<b>699200</b>	<b>1150500</b>	<b>1327500</b>	
22	79.5	Input power - HP	110	170	280	390	630	<b>910</b>	<b>1490</b>	<b>1740</b>	
		Output torque -lb-in	85000	123900	212400	312400	496500	<b>699200</b>	<b>1150500</b>	<b>1398300</b>	
25	70.0	Input power - HP	110	150	270	370	600	<b>810</b>	1260	<b>1640</b>	
		Output torque -lb-in	93800	123900	226600	313300	518600	<b>699200</b>	1124000	<b>1416000</b>	
28	62.5	Input power - HP	120	110	240	280	540	630	1150	1260	
		Output torque -lb-in	97400	106200	226600	274400	518600	623900	1150500	1256700	
32	54.7	Input power - HP	90	110	210	280	460	610	1020	1210	
		Output torque -lb-in	97400	118600	226600	307100	518600	660200	1150500	1354100	
36	48.6	Input power - HP	80	100	190	250	420	580	900	1130	
		Output torque -lb-in	97400	122100	226600	309800	518600	699200	1150500	1424900	
40	43.8	Input power - HP	70	90	170	220	370	500	790	1000	
		Output torque -lb-in	97400	123900	226600	311500	518600	700900	1150500	1424900	
45	38.9	Input power - HP	70	80	150	200	350	450	730	870	
		Output torque -lb-in	97400	123900	226600	312400	518600	700900	1150500	1424900	
50	35.0	Input power - HP	60	70	130	190	300	400	630	810	
		Output torque -lb-in	97400	123900	226600	313300	518600	700900	1150500	1424900	
56	31.3	Input power - HP	50	70	120	160	270	360	560	660	
		Output torque -lb-in	97400	123900	226600	305300	518600	660200	1150500	1327500	
63	27.8	Input power - HP	50	60	110	140	240	320	490	620	
		Output torque -lb-in	97400	123900	226600	311500	518600	700900	1150500	1424900	
71	24.6	Input power - HP	-	50	90	130	220	290	460	540	
		Output torque -lb-in	-	123900	226600	312400	518600	700900	1150500	1424900	
80	21.9	Input power - HP	-	50	80	120	190	260	400	510	
		Output torque -lb-in	-	123900	226600	313300	518600	700900	1150500	1424900	
90	19.4	Input power - HP	-	-	70	100	170	220	370	450	
		Output torque -lb-in	-	-	226600	313300	455800	655800	1150500	1433700	
100	17.5	Input power - HP	-	-	70	90	160	210	330	420	
		Output torque -lb-in	-	-	226600	313300	471700	701800	1150500	1433700	
112	15.6	Input power - HP	-	-	60	80	140	170	290	370	
		Output torque -lb-in	-	-	226600	307100	492100	640700	1150500	1433700	
125	14.0	Input power - HP	-	-	50	70	120	170	270	320	
		Output torque -lb-in	-	-	226600	313300	504500	701800	1150500	1433700	
140	12.5	Input power - HP	-	-	50	70	110	150	230	300	
		Output torque -lb-in	-	-	226600	313300	518600	701800	1150500	1433700	
160	10.9	Input power - HP	-	-	40	50	100	130	200	250	
		Output torque -lb-in	-	-	226600	311500	518600	701800	1150500	1433700	
180	9.7	Input power - HP	-	-	40	50	90	120	180	220	
		Output torque -lb-in	-	-	226600	312400	518600	701800	1150500	1433700	
200	8.8	Input power - HP	-	-	30	40	80	110	170	210	
		Output torque -lb-in	-	-	226600	313300	518600	701800	1150500	1433700	
225	7.8	Input power - HP	-	-	30	40	70	90	150	190	
		Output torque -lb-in	-	-	226600	265500	518600	701800	1150500	1433700	
250	7.0	Input power - HP	-	-	30	30	60	80	130	160	
		Output torque -lb-in	-	-	226600	278800	518600	701800	1150500	1433700	
280	6.3	Input power - HP	-	-	-	30	-	80	120	140	
		Output torque -lb-in	-	-	-	312400	-	701800	1150500	1433700	
315	5.6	Input power - HP	-	-	-	30	-	70	-	130	
		Output torque -lb-in	-	-	-	313300	-	701800	-	1433700	



TRIPLE REDUCTION

QUADRUPLE REDUCTION

**Bold Text: Forced lubrication System Required**

# SERIES G

## RIGHT ANGLE SHAFT MECHANICAL RATINGS AT 1450 RPM INPUT

Nominal Ratio Column Entry	Nominal Output Speed RPM	Mechanical Capacity	RIGHT ANGLE SHAFT UNITS - SIZE							
			G14	G15	G16	G17	G18	G19	G21	G22
8.0	181	Input power - HP	230	-	490	-	1030	-	-	-
		Output torque -lb-in	74300	-	167300	-	341600	-	-	-
9.0	161	Input power - HP	220	-	490	-	1030	-	<b>2010</b>	-
		Output torque -lb-in	83200	-	180500	-	377000	-	<b>778800</b>	-
10	145	Input power - HP	220	-	490	-	1030	-	<b>2010</b>	<b>2010</b>
		Output torque -lb-in	89400	-	197400	-	431900	-	<b>858500</b>	<b>874400</b>
11	129	Input power - HP	210	-	490	-	1030	-	<b>2010</b>	<b>2010</b>
		Output torque -lb-in	95600	-	224800	-	480600	-	<b>973500</b>	<b>964700</b>
12	116	Input power - HP	190	220	440	500	1020	1030	<b>2010</b>	<b>2010</b>
		Output torque -lb-in	97400	112400	225700	259300	518600	541600	<b>1062000</b>	<b>1097400</b>
14	104	Input power - HP	170	210	390	490	910	1030	<b>1920</b>	<b>2010</b>
		Output torque -lb-in	97400	119500	226600	289400	518600	602700	<b>1141700</b>	<b>1194800</b>
16	91	Input power - HP	160	190	340	460	780	1030	<b>1710</b>	<b>2000</b>
		Output torque -lb-in	97400	121200	226600	307100	518600	658400	<b>1150500</b>	<b>1327500</b>
18	81	Input power - HP	140	170	300	420	710	970	<b>1510</b>	<b>1840</b>
		Output torque -lb-in	97400	122100	226600	308900	518600	699200	<b>1150500</b>	<b>1371800</b>
20	72.5	Input power - HP	120	150	280	370	620	840	<b>1320</b>	<b>1650</b>
		Output torque -lb-in	97400	123900	226600	311500	518600	699200	<b>1150500</b>	<b>1398300</b>
22	65.9	Input power - HP	90	140	250	330	550	760	<b>1230</b>	<b>1480</b>
		Output torque -lb-in	84500	123900	209700	312400	517700	699200	<b>1150500</b>	<b>1424900</b>
25	58.0	Input power - HP	90	120	220	300	500	670	1040	<b>1370</b>
		Output torque -lb-in	94700	123900	226600	313300	518600	700000	1124000	<b>1424900</b>
28	51.8	Input power - HP	90	90	200	250	450	550	950	1040
		Output torque -lb-in	97400	106200	226600	289400	518600	648700	1150500	1247900
32	45.3	Input power - HP	80	90	170	230	380	530	840	1000
		Output torque -lb-in	97400	118600	226600	307100	518600	682300	1150500	1354100
36	40.3	Input power - HP	70	90	150	210	350	480	740	940
		Output torque -lb-in	97400	123900	226600	308900	518600	700000	1150500	1424900
40	36.3	Input power - HP	60	80	140	190	400	410	650	830
		Output torque -lb-in	97400	123900	226600	311500	518600	700900	1150500	1424900
45	32.2	Input power - HP	60	70	130	160	290	370	600	730
		Output torque -lb-in	97400	123900	226600	312400	518600	692100	1150500	1424900
50	29.0	Input power - HP	50	60	110	150	250	330	520	680
		Output torque -lb-in	97400	123900	226600	313300	518600	700900	1150500	1424900
56	25.9	Input power - HP	50	60	100	130	230	300	460	550
		Output torque -lb-in	97400	123900	226600	309800	518600	663800	1150500	1327500
63	23.0	Input power - HP	40	50	90	120	200	270	400	520
		Output torque -lb-in	97400	123900	226600	311500	518600	700900	1150500	1424900
71	20.4	Input power - HP	-	40	80	100	180	240	380	450
		Output torque -lb-in	-	123900	226600	311500	518600	700900	1150500	1433700
80	18.1	Input power - HP	-	40	70	100	160	210	330	420
		Output torque -lb-in	-	123900	226600	312400	518600	701800	1150500	1433700
90	16.1	Input power - HP	-	-	60	80	140	190	310	370
		Output torque -lb-in	-	-	226600	312400	482300	693800	1150500	1433700
100	14.5	Input power - HP	-	-	50	70	130	170	270	350
		Output torque -lb-in	-	-	226600	313300	499100	701800	1150500	1433700
112	12.9	Input power - HP	-	-	50	70	110	140	240	300
		Output torque -lb-in	-	-	226600	311500	518600	657600	1150500	1433700
125	11.6	Input power - HP	-	-	40	60	100	140	220	270
		Output torque -lb-in	-	-	226600	312400	518600	701800	1150500	1433700
140	10.4	Input power - HP	-	-	40	50	90	120	190	250
		Output torque -lb-in	-	-	226600	313300	518600	701800	1150500	1433700
160	9.1	Input power - HP	-	-	30	50	80	110	160	210
		Output torque -lb-in	-	-	226600	311500	518600	701800	1150500	1433700
180	8.1	Input power - HP	-	-	30	40	70	100	150	180
		Output torque -lb-in	-	-	226600	312400	518600	701800	1150500	1433700
200	7.3	Input power - HP	-	-	30	40	60	90	140	170
		Output torque -lb-in	-	-	226600	313300	518600	701800	1150500	1433700
225	6.4	Input power - HP	-	-	20	30	60	80	120	160
		Output torque -lb-in	-	-	226600	265500	518600	701800	1150500	1433700
250	5.8	Input power - HP	-	-	20	30	50	70	110	140
		Output torque -lb-in	-	-	226600	278800	518600	701800	1150500	1433700
280	5.2	Input power - HP	-	-	-	30	-	60	100	120
		Output torque -lb-in	-	-	-	312400	-	701800	1150500	1433700
315	4.6	Input power - HP	-	-	-	20	-	60	-	110
		Output torque -lb-in	-	-	-	313300	-	701800	-	1433700

TRIPLE REDUCTION

QUADRUPLE REDUCTION

**Bold Text: Forced Lubrication System Required**

# SERIES G

## RIGHT ANGLE SHAFT MECHANICAL RATINGS AT 1160 RPM INPUT



Nominal Ratio Column Entry	Nominal Output Speed RPM	Mechanical Capacity	RIGHT ANGLE SHAFT UNITS - SIZE								
			G14	G15	G16	G17	G18	G19	G21	G22	
8.0	145	Input power - HP	190	-	400	-	820	-	-	-	
		Output torque -lb-in	74800	-	170800	-	340700	-	-	-	
9.0	129	Input power - HP	180	-	400	-	820	-	1610	-	
		Output torque -lb-in	83000	-	184100	-	376100	-	778800	-	
10	116	Input power - HP	170	-	400	-	820	-	1610	1610	
		Output torque -lb-in	89400	-	200900	-	431000	-	858500	872600	
11	104	Input power - HP	170	-	390	-	820	-	1610	1610	
		Output torque -lb-in	95600	-	226600	-	479700	-	973500	964700	
12	93	Input power - HP	150	170	350	400	810	820	1610	1610	
		Output torque -lb-in	97400	112400	226600	259300	518600	540700	1062000	1088600	
14	83	Input power - HP	140	170	320	400	730	820	1540	1610	
		Output torque -lb-in	97400	119500	226600	293800	518600	601800	1141700	1194800	
16	73	Input power - HP	130	150	280	370	620	820	1370	1610	
		Output torque -lb-in	97400	121200	226600	307100	516800	657600	1150500	1336400	
18	64	Input power - HP	110	140	240	330	570	780	1210	1530	
		Output torque -lb-in	97400	122100	226600	309800	518600	699200	1150500	1424900	
20	58.0	Input power - HP	100	120	230	300	500	670	1060	1340	
		Output torque -lb-in	97400	123900	226600	311500	518600	700000	1150500	1424900	
22	52.7	Input power - HP	70	110	200	260	440	610	980	1180	
		Output torque -lb-in	84500	123900	223900	312400	518600	700000	1150500	1424900	
25	46.4	Input power - HP	70	100	180	240	400	540	830	1100	
		Output torque -lb-in	93800	123900	226600	313300	518600	700000	1124000	1424900	
28	41.4	Input power - HP	70	70	160	200	360	440	760	830	
		Output torque -lb-in	97400	106200	226600	292100	518600	648700	1150500	1247900	
32	36.3	Input power - HP	60	70	140	190	310	420	670	800	
		Output torque -lb-in	97400	118600	226600	307100	518600	682300	1150500	1345200	
36	32.2	Input power - HP	60	70	120	170	280	380	600	750	
		Output torque -lb-in	97400	122100	226600	309800	518600	700900	1150500	1424900	
40	29.0	Input power - HP	50	60	110	150	250	330	520	670	
		Output torque -lb-in	97400	123900	226600	311500	518600	700900	1150500	1424900	
45	25.8	Input power - HP	40	50	100	130	230	300	480	580	
		Output torque -lb-in	97400	123900	226600	312400	518600	700900	1150500	1424900	
50	23.2	Input power - HP	40	50	90	120	200	260	420	540	
		Output torque -lb-in	97400	123900	226600	313300	518600	700900	1150500	1424900	
56	20.7	Input power - HP	40	40	80	110	180	240	370	440	
		Output torque -lb-in	97400	123900	226600	309800	518600	663800	1150500	1327500	
63	18.4	Input power - HP	30	40	70	90	160	210	320	410	
		Output torque -lb-in	97400	123900	226600	311500	518600	700900	1150500	1433700	
71	16.3	Input power - HP	-	40	60	80	150	190	300	360	
		Output torque -lb-in	-	123900	226600	312400	518600	700900	1150500	1433700	
80	14.5	Input power - HP	-	30	60	80	130	170	270	340	
		Output torque -lb-in	-	123900	226600	313300	518600	701800	1150500	1433700	
90	12.9	Input power - HP	-	-	50	60	110	160	250	300	
		Output torque -lb-in	-	-	226600	312400	516000	701800	1150500	1433700	
100	11.6	Input power - HP	-	-	40	60	100	140	220	280	
		Output torque -lb-in	-	-	226600	313300	518600	701800	1150500	1433700	
112	10.4	Input power - HP	-	-	40	50	90	120	190	240	
		Output torque -lb-in	-	-	226600	311500	518600	681500	1150500	1433700	
125	9.3	Input power - HP	-	-	30	50	80	110	180	210	
		Output torque -lb-in	-	-	226600	312400	518600	701800	1150500	1433700	
140	8.3	Input power - HP	-	-	30	40	70	100	150	200	
		Output torque -lb-in	-	-	226600	313300	518600	701800	1150500	1433700	
160	7.3	Input power - HP	-	-	30	40	70	90	130	170	
		Output torque -lb-in	-	-	226600	311500	518600	701800	1150500	1433700	
180	6.4	Input power - HP	-	-	20	30	60	80	120	150	
		Output torque -lb-in	-	-	208000	312400	518600	701800	1150500	1433700	
200	5.8	Input power - HP	-	-	20	30	50	70	110	140	
		Output torque -lb-in	-	-	216800	313300	518600	701800	1150500	1433700	
225	5.2	Input power - HP	-	-	20	20	50	60	100	130	
		Output torque -lb-in	-	-	226600	265500	518600	701800	1150500	1433700	
250	4.6	Input power - HP	-	-	20	20	40	60	80	110	
		Output torque -lb-in	-	-	226600	278800	518600	701800	1150500	1433700	
280	4.1	Input power - HP	-	-	-	20	-	50	80	90	
		Output torque -lb-in	-	-	-	312400	-	701800	1150500	1433700	
315	3.7	Input power - HP	-	-	-	20	-	40	-	90	
		Output torque -lb-in	-	-	-	313300	-	701800	-	1433700	

TRIPLE REDUCTION

QUADRUPLE REDUCTION

# SERIES G

## RIGHT ANGLE SHAFT MECHANICAL RATINGS AT 875 RPM INPUT

Nominal Ratio Column Entry	Nominal Output Speed RPM	Mechanical Capacity	RIGHT ANGLE SHAFT UNITS - SIZE								
			G14	G15	G16	G17	G18	G19	G21	G22	
8.0	109	Input power - HP	140	-	300	-	620	-	-	-	
		Output torque -lb-in	74800	-	169900	-	339800	-	-	-	
9.0	97	Input power - HP	130	-	300	-	620	-	1220	-	
		Output torque -lb-in	83000	-	184100	-	375200	-	778800	-	
10	88	Input power - HP	130	-	300	-	620	-	1220	1220	
		Output torque -lb-in	89400	-	200900	-	430100	-	858500	870800	
11	78	Input power - HP	130	-	300	-	620	-	1220	1220	
		Output torque -lb-in	95600	-	226600	-	479700	-	973500	964700	
12	70	Input power - HP	120	130	270	300	610	620	1220	1220	
		Output torque -lb-in	97400	112400	226600	258400	518600	539900	1062000	1088600	
14	63	Input power - HP	110	130	240	300	550	620	1160	1220	
		Output torque -lb-in	97400	119500	226600	293800	518600	601800	1141700	1194800	
16	55	Input power - HP	90	110	210	280	470	620	1030	1220	
		Output torque -lb-in	97400	121200	226600	307100	518600	656700	1150500	1336400	
18	49	Input power - HP	80	100	180	250	430	590	910	1150	
		Output torque -lb-in	97400	122100	226600	308900	518600	700000	1150500	1424900	
20	43.8	Input power - HP	70	90	170	220	380	510	800	1020	
		Output torque -lb-in	97400	123900	226600	311500	518600	700000	1150500	1424900	
22	39.8	Input power - HP	60	80	150	200	330	460	740	890	
		Output torque -lb-in	84500	123900	226600	312400	518600	700000	1150500	1424900	
25	35.0	Input power - HP	60	70	130	180	300	410	630	830	
		Output torque -lb-in	94700	123900	226600	313300	518600	700900	1115100	1424900	
28	31.3	Input power - HP	50	60	120	150	270	330	570	630	
		Output torque -lb-in	97400	106200	226600	292100	518600	650500	1150500	1247900	
32	27.3	Input power - HP	50	60	110	140	230	320	510	600	
		Output torque -lb-in	97400	118600	226600	307100	518600	682300	1150500	1345200	
36	24.3	Input power - HP	40	50	90	130	210	290	450	570	
		Output torque -lb-in	97400	123900	226600	308900	518600	700900	1150500	1424900	
40	21.9	Input power - HP	40	50	90	110	190	250	390	500	
		Output torque -lb-in	97400	123900	226600	311500	518600	700900	1150500	1424900	
45	19.4	Input power - HP	30	40	80	100	170	230	370	440	
		Output torque -lb-in	97400	123900	226600	312400	518600	700900	1150500	1433700	
50	17.5	Input power - HP	30	40	70	90	150	200	320	410	
		Output torque -lb-in	97400	123900	226600	313300	518600	701800	1150500	1433700	
56	15.6	Input power - HP	30	30	60	80	140	180	280	330	
		Output torque -lb-in	97400	123900	226600	309800	518600	663800	1150500	1327500	
63	13.9	Input power - HP	20	30	50	70	120	160	240	310	
		Output torque -lb-in	97400	123900	226600	311500	518600	700900	1150500	1433700	
71	12.3	Input power - HP	-	30	50	60	110	150	230	270	
		Output torque -lb-in	-	123900	226600	312400	518600	701800	1150500	1433700	
80	10.9	Input power - HP	-	20	40	60	100	130	200	250	
		Output torque -lb-in	-	123900	226600	313300	518600	70200	1150500	1433700	
90	9.7	Input power - HP	-	-	40	50	90	120	190	220	
		Output torque -lb-in	-	-	226600	312400	518600	701800	1150500	1433700	
100	8.8	Input power - HP	-	-	30	50	80	110	160	210	
		Output torque -lb-in	-	-	226600	313300	518600	701800	1150500	1433700	
112	7.8	Input power - HP	-	-	30	40	70	90	140	180	
		Output torque -lb-in	-	-	226600	312400	518600	701800	1150500	1433700	
125	7.0	Input power - HP	-	-	30	40	60	80	130	160	
		Output torque -lb-in	-	-	226600	312400	518600	701800	1150500	1433700	
140	6.3	Input power - HP	-	-	20	30	60	70	110	150	
		Output torque -lb-in	-	-	226600	313300	518600	701800	1150500	1433700	
160	5.5	Input power - HP	-	-	20	30	50	70	100	130	
		Output torque -lb-in	-	-	226600	313300	518600	701800	1150500	1433700	
180	4.9	Input power - HP	-	-	20	20	40	60	90	110	
		Output torque -lb-in	-	-	208000	313300	518600	701800	1150500	1433700	
200	4.4	Input power - HP	-	-	20	20	40	50	90	100	
		Output torque -lb-in	-	-	216800	313300	518600	701800	1150500	1433700	
225	3.9	Input power - HP	-	-	10	20	40	50	70	100	
		Output torque -lb-in	-	-	227400	265500	518600	701800	1150500	1433700	
250	3.5	Input power - HP	-	-	10	20	30	40	60	80	
		Output torque -lb-in	-	-	227400	278800	518600	701800	1150500	1433700	
280	3.1	Input power - HP	-	-	-	20	-	40	60	70	
		Output torque -lb-in	-	-	-	313300	-	701800	1150500	1451400	
315	2.8	Input power - HP	-	-	-	20	-	30	-	70	
		Output torque -lb-in	-	-	-	313300	-	701800	-	1451400	

TRIPLE REDUCTION

QUADRUPLE REDUCTION

# SERIES G

## RIGHT ANGLE SHAFT

### THERMAL RATINGS

#### Thermal Ratings HP

These thermal ratings assume the gear unit is in constant use working in an ambient temperature of 77°F (25°C)\* installed in a large indoor space at sea level.

These ratings must be adjusted for alternative operating and environment conditions refer to Thermal ratings and service factors on page 6. Ratings are for reference purposes. Contact Application Engineering to confirm suitability for your application.

\*maximum bulk oil temperature 203°F (95°C)

#### Right Angle Shaft Units - Triple Reduction

Type of Cooling	Input Speed (rev/min)	Ratio	G1430	G1530	G1630	G1730	G1830	G1930	G2130	G2230
No Additional Cooling	1750	12:1	89	96	143	136	223	196	236	250
		25:1	67	77	119	116	186	166	207	222
		56:1	41	50	82	84	130	119	156	173
	1450	12:1	86	93	143	139	230	215	279	295
		25:1	66	75	120	120	194	185	248	265
		56:1	41	50	84	88	138	136	192	212
	1160	12:1	84	89	143	141	236	231	315	331
		25:1	66	73	121	122	201	201	283	301
		56:1	42	50	86	91	145	151	224	244
	875	12:1	82	86	141	140	236	238	333	349
		25:1	64	71	120	123	202	208	300	319
		56:1	41	49	86	92	148	158	240	262
Fan Cooling	1750	12:1	240	243	386	382	650	725	1024	1053
		25:1	206	216	350	354	592	674	968	1003
		56:1	149	167	282	296	479	568	850	897
	1450	12:1	212	215	347	345	584	655	933	962
		25:1	181	190	314	318	530	606	880	915
		56:1	129	145	250	264	425	508	768	813
	1160	12:1	185	188	308	307	520	586	843	871
		25:1	157	165	277	282	469	540	792	825
		56:1	111	125	219	232	373	449	687	729
	875	12:1	163	167	277	277	467	529	767	794
		25:1	137	146	248	253	420	486	719	751
		56:1	96	109	194	207	332	401	620	660
Cooling Coil	1750	12:1	233	242	377	379	634	642	743	768
		25:1	199	215	342	350	576	592	692	722
		56:1	142	165	275	293	465	492	588	627
	1450	12:1	226	234	371	374	626	640	755	780
		25:1	194	209	337	346	570	591	705	736
		56:1	140	162	272	291	462	493	602	642
	1160	12:1	219	227	365	369	619	638	765	792
		25:1	189	203	332	342	564	590	716	748
		56:1	137	158	269	288	459	495	616	655
	875	12:1	212	220	356	361	605	627	761	788
		25:1	183	196	324	335	552	581	713	745
		56:1	133	153	263	283	451	489	615	654
Fan and Cooling Coil	1750	12:1	333	338	535	535	913	988	1297	1330
		25:1	296	309	497	505	849	932	1238	1278
		56:1	227	252	420	441	719	815	1110	1164
	1450	12:1	309	314	503	504	858	929	1218	1251
		25:1	274	287	466	475	797	875	1161	1201
		56:1	209	233	392	413	672	762	1038	1090
	1160	12:1	286	291	471	474	804	871	1141	1173
		25:1	252	265	436	446	745	819	1085	1124
		56:1	192	214	364	386	626	710	966	1017
	875	12:1	266	272	442	446	755	818	1070	1102
		25:1	234	246	409	419	699	768	1017	1055
		56:1	177	199	341	362	586	664	903	952

#### Right Angle Shafts - Quadruple Reduction

Type of Cooling	Input Speed (rev/min)	Ratio	G1440	G1540	G1640	G1740	G1840	G1940	G2140	G2240
No Additional Cooling	1750	100:1	-	-	83	82	111	100	123	125
		250:1	-	-	60	61	85	79	97	102
	1450	100:1	-	-	82	82	115	109	146	148
		250:1	-	-	60	63	89	88	117	123
	1160	100:1	-	-	82	82	119	118	165	167
		250:1	-	-	61	64	93	97	135	140
875	100:1	-	-	80	82	119	121	175	176	
	250:1	-	-	60	64	94	100	144	149	



# SERIES G



## DIMENSIONS HORIZONTAL RIGHT ANGLE SHAFTS TRIPLE REDUCTION

DIMENSIONS IN mm

**G** **30** **B** Triple Reduction Right Angle Units Horizontal

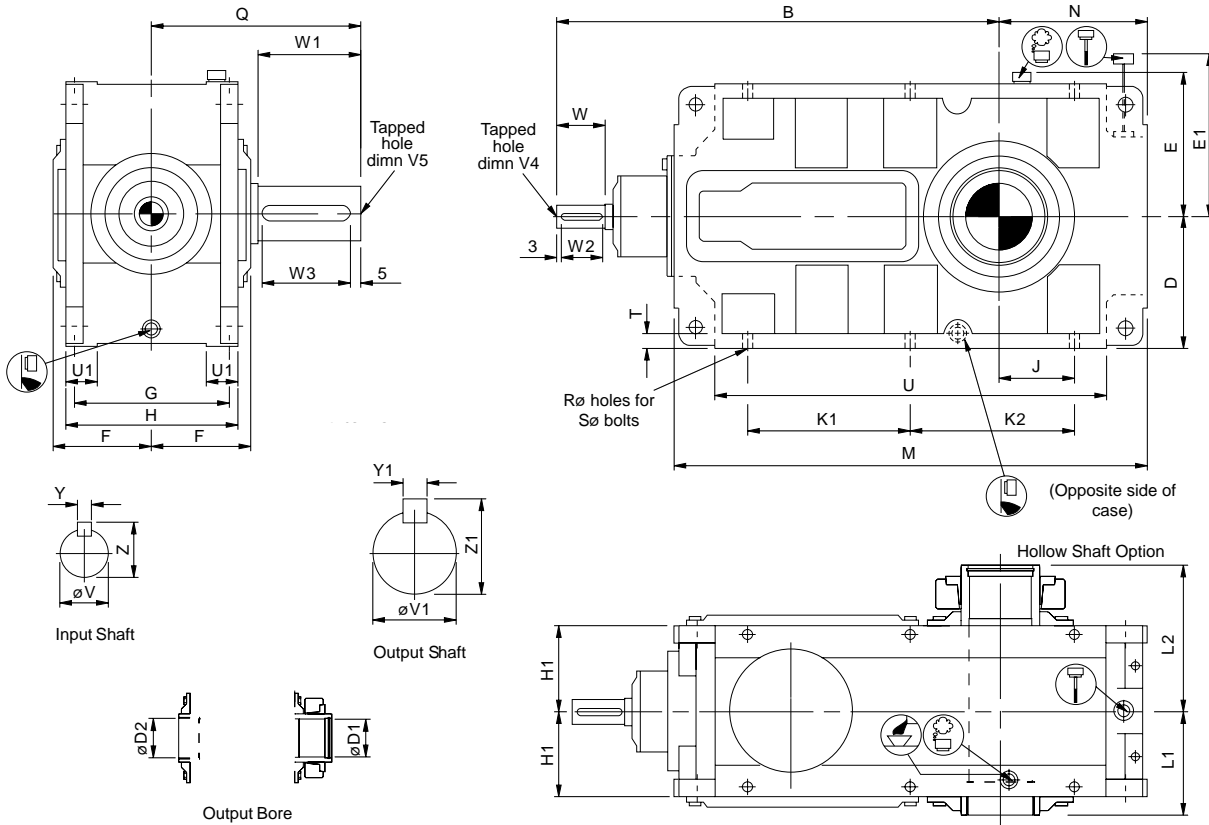

Unit Size	B	D	E	E1	F	G	H	H1	J	K1	K2	M	N	Q	R	S	T	U	U1
G14	720	230	250	370	177	265	300	150	170	285	820	295	360	18.5	6 x m16 x 60*	25	684	55	
G15	760	230	250	370	177	265	300	150	130	285	820	255	370	18.5	6 x m16 x 60*	25	684	55	
G16	940	300	335	515	225	330	380	190	225	385	1060	370	460	28	6 x m24 x 80*	30	898	70	
G17	995	300	335	515	225	330	380	190	170	385	1060	315	480	28	6 x m24 x 80*	30	898	70	
G18	1220	385	420	710	290	440	500	250	153	520	350	1240	338	600	33	6 x m30 x 100*	37	1036	90
G19	1285	385	420	710	290	440	500	250	220	500	1374	407	650	33	6 x m30 x 100*	40	1170	90	
G21	1630	465	507	750	340	530	600	300	225	695	480	1655	465	700	39	6 x m36 x 100*	50	1380	120
G22	1670	465	507	750	340	530	600	300	245	745	490	1715	485	730	39	6 x m36 x 100*	50	1440	120

Unit Size	Input Shaft ●						Output Shaft ●						Output Bore ●			
	V	V4	W	W2	Y	Z	V1	V5	W1	W3	Y1	Z1	D1	D2	L1	L2
G14	38 k6	M12 x 32	100	90	10	41	110 m6	M30 x 63	180	170	28	116	95	100	180	255
G15	38 k6	M12 x 32	100	90	10	41	130 m6	M30 x 63	190	180	32	137	110	115	180	260
G16	50 k6	M16 x 36	140	130	14	53.5	145 m6	M42 x 81	230	220	36	153	125	130	230	325
G17	50 k6	M16 x 36	140	130	14	53.5	170 m6	M42 x 81	250	240	40	179	145	150	230	340
G18	75 m6	M20 x 43	160	150	20	79.5	190 m6	M42 x 81	300	290	45	200	160	170	300	410
G19	75 m6	M20 x 43	160	150	20	79.5	210 m6	M42 x 81	350	340	50	221	170	180	300	430
G21	100 m6	M24 x 52	210	200	28	106	220 m6	M42 x 81	350	340	50	231	210	220	350	500
G22	100 m6	M24 x 52	210	200	28	106	240 m6	M42 x 81	380	340	56	252	230	240	350	515

**DIMENSIONS HORIZONTAL RIGHT ANGLE  
SHAFTS TRIPLE REDUCTION**

DIMENSIONS IN inch

**G 3 0 B Triple Reduction Right Angle Units Horizontal**

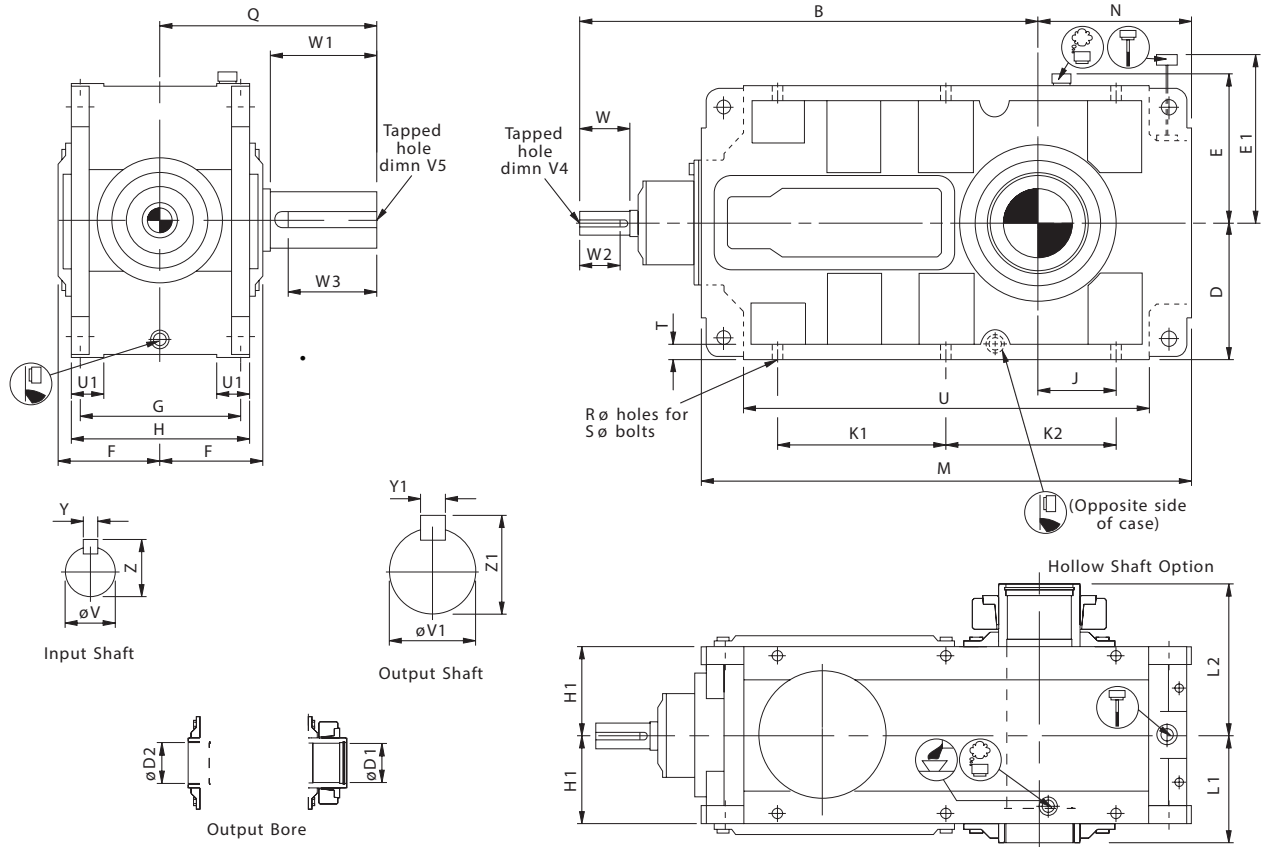

Unit Size	B	D	E	E1	F	G	H	H1	J	K1	K2	M	N	Q	R	S	T	U	U1
G14	28.35	9.06	9.84	14.57	6.97	10.43	11.81	5.91	6.69	11.22	32.28	11.61	14.17	0.73	6 x m16 x 60*	0.98	26.93	2.17	
G15	29.92	9.06	9.84	14.57	6.97	10.43	11.81	5.91	5.12	11.22	32.28	10.04	14.57	0.73	6 x m16 x 60*	0.98	26.93	2.17	
G16	37.01	11.81	13.19	20.28	8.86	12.99	14.96	7.48	8.86	15.16	41.73	14.57	18.11	1.10	6 X m24 X 80*	1.18	35.35	2.76	
G17	39.17	11.81	13.19	20.28	8.86	12.99	14.96	7.48	6.69	15.16	41.73	12.40	18.90	1.10	6 X m24 X 80*	1.18	35.35	2.76	
G18	48.03	15.16	16.54	27.95	11.42	17.32	19.69	9.84	6.02	20.47	13.78	48.82	13.31	23.62	1.30	6 x m30 x 100*	1.46	40.79	3.54
G19	50.59	15.16	16.54	27.95	11.42	17.32	19.69	9.84	8.66	19.69	54.09	16.02	25.59	1.30	6 x m30 x 100*	1.57	46.06	3.54	
G21	64.17	18.31	19.96	29.53	13.39	20.87	23.62	11.81	8.86	27.36	18.90	65.16	18.31	27.56	1.54	6 x m36 x 100*	1.97	54.33	4.72
G22	65.75	18.31	19.96	29.53	13.39	20.87	23.62	11.81	9.65	29.33	19.29	67.52	19.09	28.74	1.54	6 x m36 x 100*	1.97	56.69	4.72

Unit Size	Input Shaft						Output Shaft						Output Bore			
	V	V4	W	W2	Y	Z	V1	V5	W1	W3	Y1	Z1	D1	D2	L1	L2
G14	1.500	5/8 UNF x 1.25	3.94	3.00	0.313	1.60	4.500	1 UNF x 2	7.09	6.50	1.00	4.94	3.74	3.94	7.09	10.04
G15	1.500	5/8 UNF x 1.25	3.94	3.00	0.313	1.60	5.000	1 UNF x 2	7.48	7.13	1.25	5.55	4.33	4.53	7.09	10.24
G16	1.875	5/8 UNF x 1.25	5.51	4.13	0.500	2.10	6.000	1.25 UNF x 2.5	9.06	8.75	1.50	6.66	4.92	5.12	9.06	12.80
G17	1.875	5/8 UNF x 1.25	5.51	4.13	0.500	2.10	6.750	1.25 UNF x 2.5	9.84	9.38	1.75	7.39	5.71	5.91	9.06	13.39
G18	3.000	3/4 UNF x 1.62	6.30	5.25	0.750	3.33	7.500	1.5 UNF x 3	11.81	11.38	1.75	8.15	6.30	6.69	11.81	16.14
G19	3.000	3/4 UNF x 1.62	6.30	5.25	0.750	3.33	8.250	1.5 UNF x 3	13.78	13.00	2.00	8.88	6.69	7.09	11.81	16.93
G21	4.000	1 UNF x 2	8.27	7.50	1.000	4.44	8.500	1.5 UNF x 3	13.78	13.00	2.00	9.13	8.27	8.66	13.78	19.69
G22	4.000	1 UNF x 2	8.27	7.50	1.000	4.44	9.250	1.5 UNF x 3	14.96	14.25	2.50	9.95	9.06	9.45	13.78	20.28

## DIMENSIONS VERTICAL RIGHT ANGLE SHAFTS TRIPLE REDUCTION

DIMENSIONS IN mm

**G** **30** **R** Triple Reduction Right Angle Units Vertical

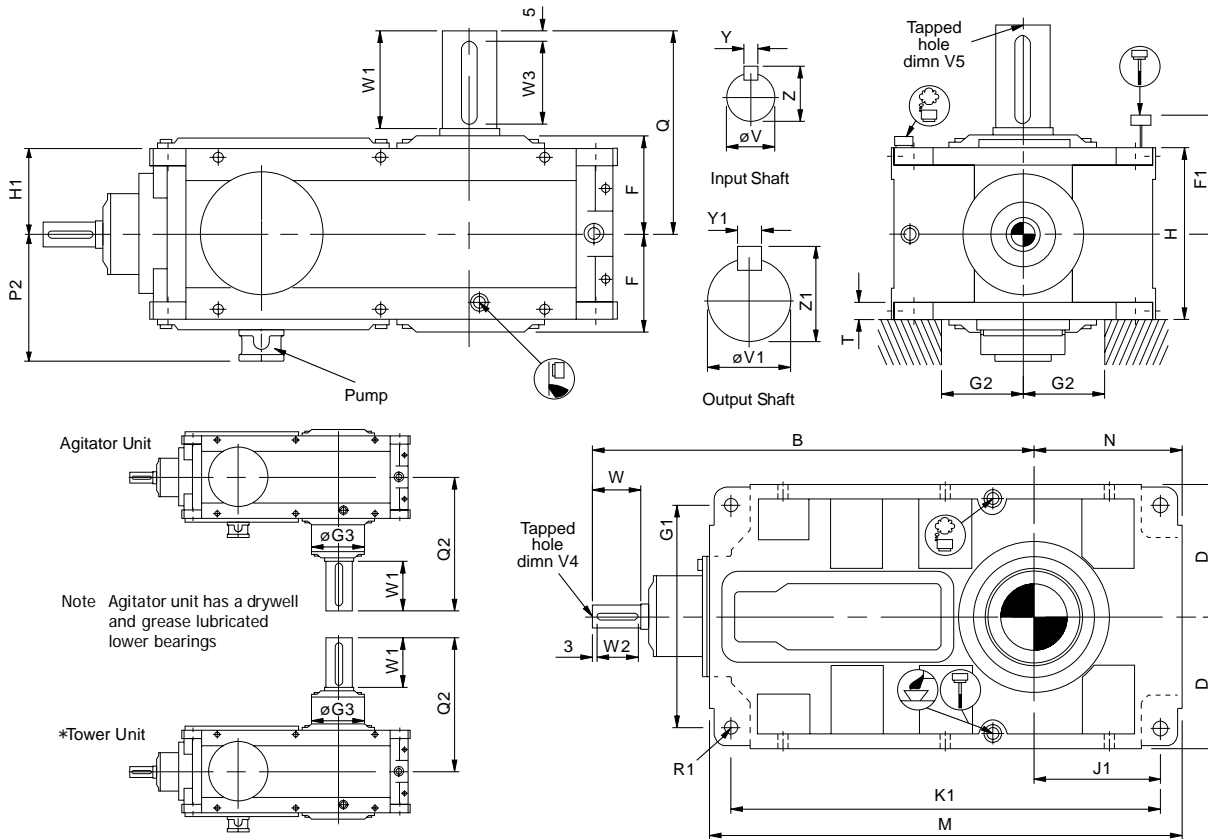

Unit Size	B	D	F	F1	G1	G2 (min)		G3	H	H1	J1	K1	M	N	P2	Q	Q2	R1	T
						No Fan	With Fan												
G14	720	230	177	390	390	135	155	230	300	150	260	750	820	295	236	360	475	4 x Ø24	30
G15	760	230	177	390	390	135	155	260	300	150	220	750	820	255	236	370	495	4 x Ø24	30
G16	940	300	225	515	506	175	205	300	380	190	325	970	1060	370	285	460	595	4 x Ø33	45
G17	995	300	225	515	506	175	205	340	380	190	270	970	1060	315	285	480	615	4 x Ø33	45
G18	1220	385	290	700	656	205	245	370	500	250	281	1126	1240	338	345	600	760	4 x Ø40	55
G19	1285	385	290	700	656	205	245	400	500	250	350	1260	1374	407	345	650	815	4 x Ø40	55
G21	1630	465	340	750	790	255	315	500	600	300	395	1515	1655	465	400	700	925	4 x Ø48	70
G22	1670	465	340	750	790	265	315	*	600	300	415	1575	1715	485	400	730	*	4 x Ø48	70

Unit Size	Input Shaft ●						Output Shaft ●					
	V	V4	W	W2	Y	Z	V1	V5	W1	W3	Y1	Z1
G14	38 k6	M12 x 32	100	90	10	41	110 m6	M30 x 63	180	170	28	116
G15	38 k6	M12 x 32	100	90	10	41	130 m6	M30 x 63	190	180	32	137
G16	50 k6	M16 x 36	140	130	14	53.5	145 m6	M42 x 81	230	220	36	153
G17	50 k6	M16 x 36	140	130	14	53.5	170 m6	M42 x 81	250	240	40	179
G18	75 m6	M20 x 43	160	150	20	79.5	190 m6	M42 x 81	300	290	45	200
G19	75 m6	M20 x 43	160	150	20	79.5	210 m6	M42 x 81	350	340	50	221
G21	100 m6	M24 x 52	210	200	28	106	220 m6	M42 x 81	350	340	50	231
G22	100 m6	M24 x 52	210	200	28	106	240 m6	M42 x 81	380	340	56	252

\* = Contact Application Engineering

## DIMENSIONS VERTICAL RIGHT ANGLE SHAFTS TRIPLE REDUCTION

DIMENSIONS IN inch

**G** **3** **0** **R** Triple Reduction Right Angle Units Horizontal

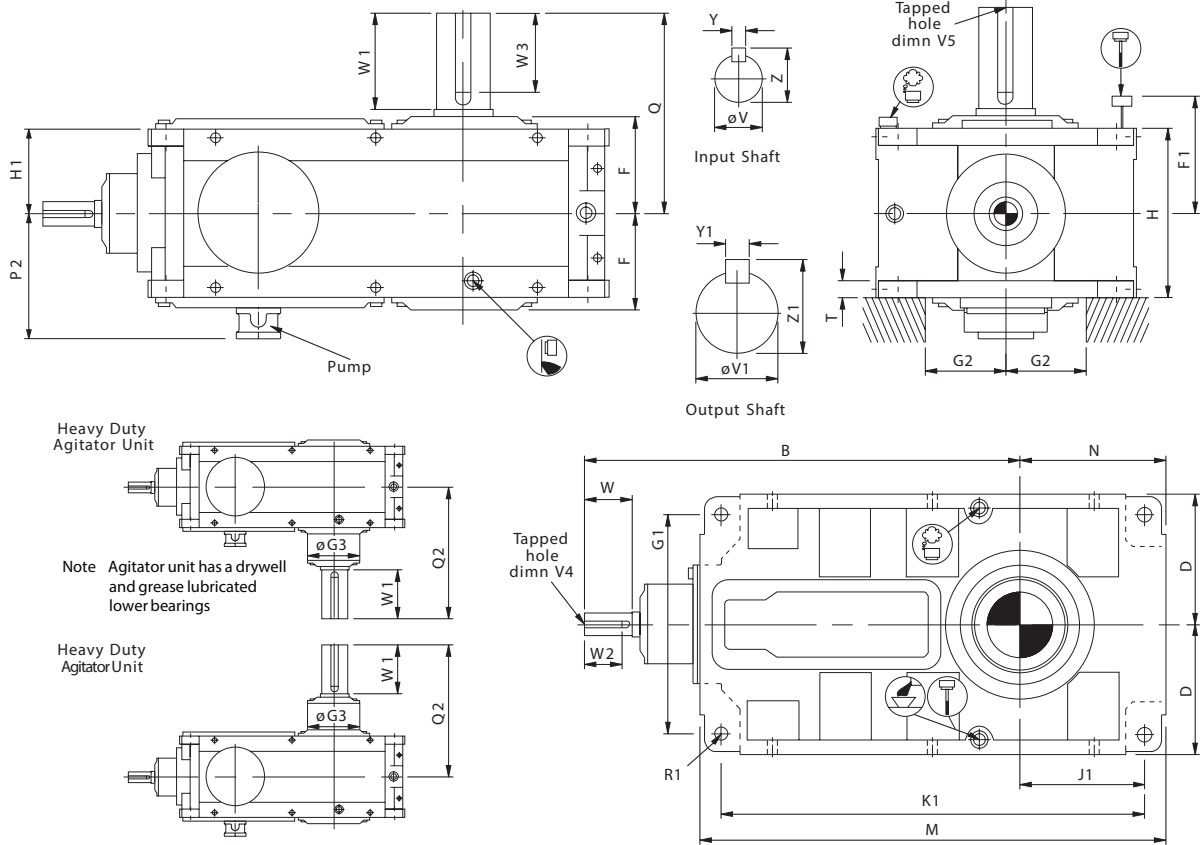

Unit Size	B	D	F	F1	G1	G2 (min)		G3	H	H1	J1	K1	M	N	P2	Q	Q2	R1	T
						No Fan	With Fan												
G14	28.35	9.06	6.97	15.35	15.35	5.31	6.10	9.06	11.81	5.91	10.24	29.53	32.28	11.61	9.29	14.17	18.70	4 x Ø24	1.18
G15	29.92	9.06	6.97	15.35	15.35	5.31	6.10	10.24	11.81	5.91	8.66	29.53	32.28	10.04	9.29	14.57	19.49	4 x Ø24	1.18
G16	37.01	11.81	8.86	20.28	19.92	6.89	8.07	11.81	14.96	7.48	12.80	38.19	41.73	14.57	11.22	18.11	23.43	4 x Ø33	1.77
G17	39.17	11.81	8.86	20.28	19.92	6.89	8.07	13.39	14.96	7.48	10.63	38.19	41.73	12.40	11.22	18.90	24.21	4 x Ø33	1.77
G18	48.03	15.16	11.42	27.56	25.83	8.07	9.65	14.57	19.69	9.84	11.06	44.33	48.82	13.31	13.58	23.62	29.92	4 x Ø40	2.17
G19	50.59	15.16	11.42	27.56	25.83	8.07	9.65	15.75	19.69	9.84	13.78	49.61	54.09	16.02	13.58	25.59	32.09	4 x Ø40	2.17
G21	64.17	18.31	13.39	29.53	31.10	10.04	12.40	19.69	23.62	11.81	15.55	59.65	65.16	18.31	15.75	27.56	36.42	4 x Ø48	2.76
G22	65.75	18.31	13.39	29.53	31.10	10.43	12.40	*	23.62	11.81	16.34	62.01	67.52	19.09	15.75	28.74	*	4 x Ø48	2.76

Unit Size	Input Shaft						Output Shaft					
	V	V4	W	W2	Y	Z	V1	V5	W1	W3	Y1	Z1
G14	1.500	5/8 UNF x 1.25	3.94	3.00	0.313	1.60	4.500	1 UNF x 2	7.09	6.50	1.00	4.94
G15	1.500	5/8 UNF x 1.25	3.94	3.00	0.313	1.60	5.000	1 UNF x 2	7.48	7.13	1.25	5.55
G16	1.875	5/8 UNF x 1.25	5.51	4.13	0.500	2.10	6.000	1.25 UNF x 2.5	9.06	8.75	1.50	6.66
G17	1.875	5/8 UNF x 1.25	5.51	4.13	0.500	2.10	6.750	1.25 UNF x 2.5	9.84	9.38	1.75	7.39
G18	3.000	3/4 UNF x 1.62	6.30	5.25	0.750	3.33	7.500	1.5 UNF x 3	11.81	11.38	1.75	8.15
G19	3.000	3/4 UNF x 1.62	6.30	5.25	0.750	3.33	8.250	1.5 UNF x 3	13.78	13.00	2.00	8.88
G21	4.000	1 UNF x 2	8.27	7.50	1.000	4.44	8.500	1.5 UNF x 3	13.78	13.00	2.00	9.13
G22	4.000	1 UNF x 2	8.27	7.50	1.000	4.44	9.250	1.5 UNF x 3	14.96	14.25	2.50	9.95

## DIMENSIONS HORIZONTAL RIGHT ANGLE SHAFTS QUADRUPLE REDUCTION

DIMENSIONS IN mm

**G** **4 0** **B** Quadruple Reduction Right Angle Units Horizontal

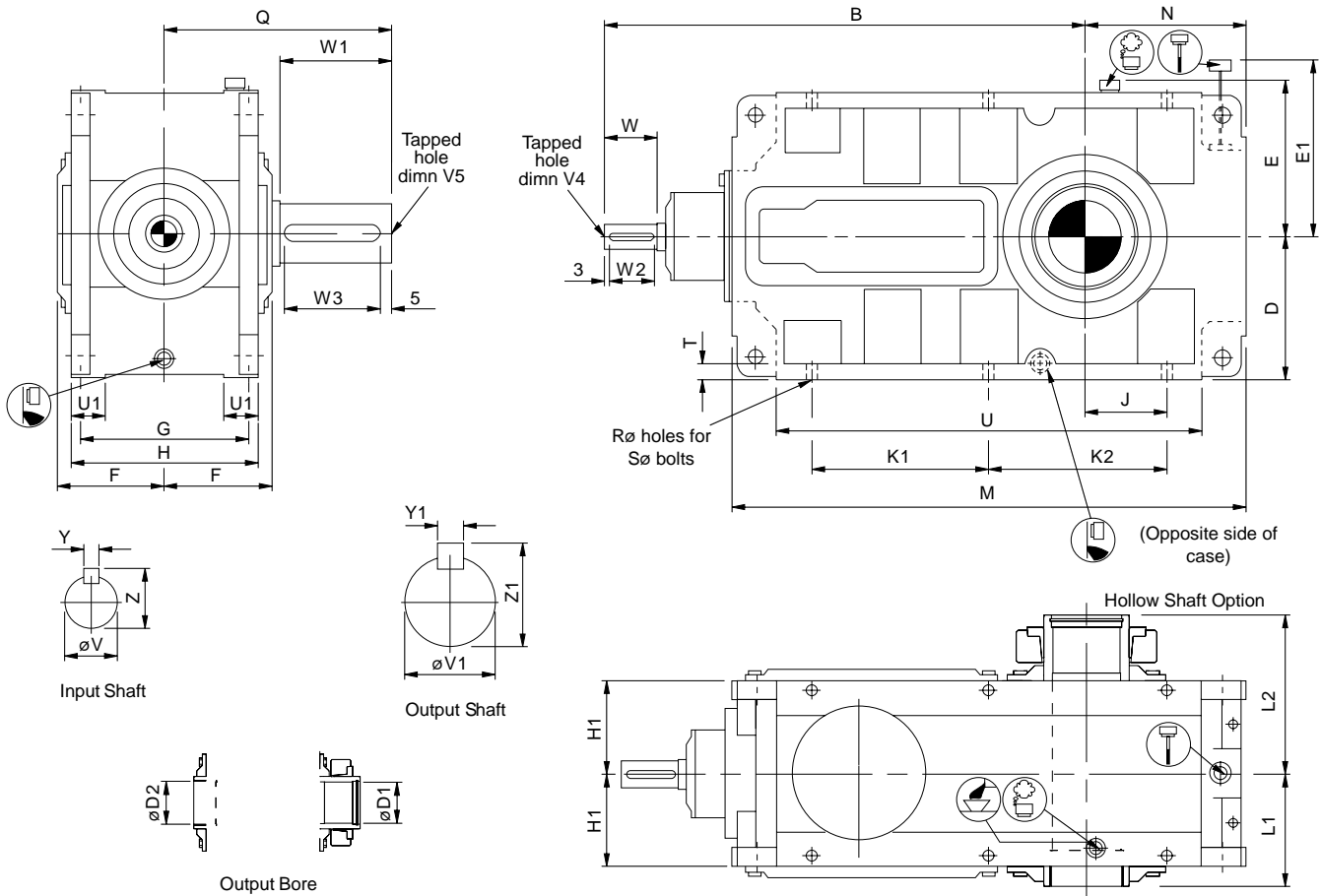

Unit Size	B	D	E	E1	F	G	H	H1	J	K1	K2	M	N	Q	R	S	T	U	U1
G16	965	300	335	515	225	330	380	190	225	385		1060	370	460	28	6 X m24 X 80*	30	898	70
G17	1020	300	335	515	225	330	380	190	170	385		1060	315	480	28	6 x m24 x 80*	30	898	70
G18	1265	385	420	710	290	440	500	250	153	520	350	1240	338	600	33	6 x m30 x 100*	37	1036	90
G19	1330	385	420	710	290	440	500	250	220	500		1374	407	650	33	6 x m30 x 100*	40	1170	90
G21	1660	465	507	750	340	530	600	300	225	695	480	1655	465	700	39	6 x m36 x 100*	50	1380	120
G22	1700	465	507	750	340	530	600	300	245	745	490	1715	485	730	39	6 x m36 x 100*	50	1440	120

Unit Size	Input Shaft ●						Output Shaft ●						Output Bore ●			
	V	V4	W	W2	Y	Z	V1	V5	W1	W3	Y1	Z1	D1	D2	L1	L2
G16	38 k6	M12 x 32	100	90	10	41	145 m6	M42 x81	230	220	36	153	125	130	230	325
G17	38 k6	M12 x 32	100	90	10	41	170 m6	M42 x81	250	240	40	179	145	150	230	340
G18	50 k6	M16 x 36	140	130	14	53.5	190 m6	M42 x81	300	290	45	200	160	170	300	410
G19	50 k6	M16 x 36	140	130	14	53.5	210 m6	M42 x81	350	340	50	221	170	180	300	430
G21	75 m6	M20 x 43	160	150	20	79.5	220 m6	M42 x81	350	340	50	231	210	220	350	500
G22	75 m6	M20 x 43	160	150	20	79.5	240 m6	M42 x81	380	340	56	252	230	240	350	515

**DIMENSIONS HORIZONTAL RIGHT ANGLE  
SHAFTS QUADRUPLE REDUCTION**

DIMENSIONS IN inch

**G 4 0 B Quadruple Reduction Right Angle Units Horizontal**

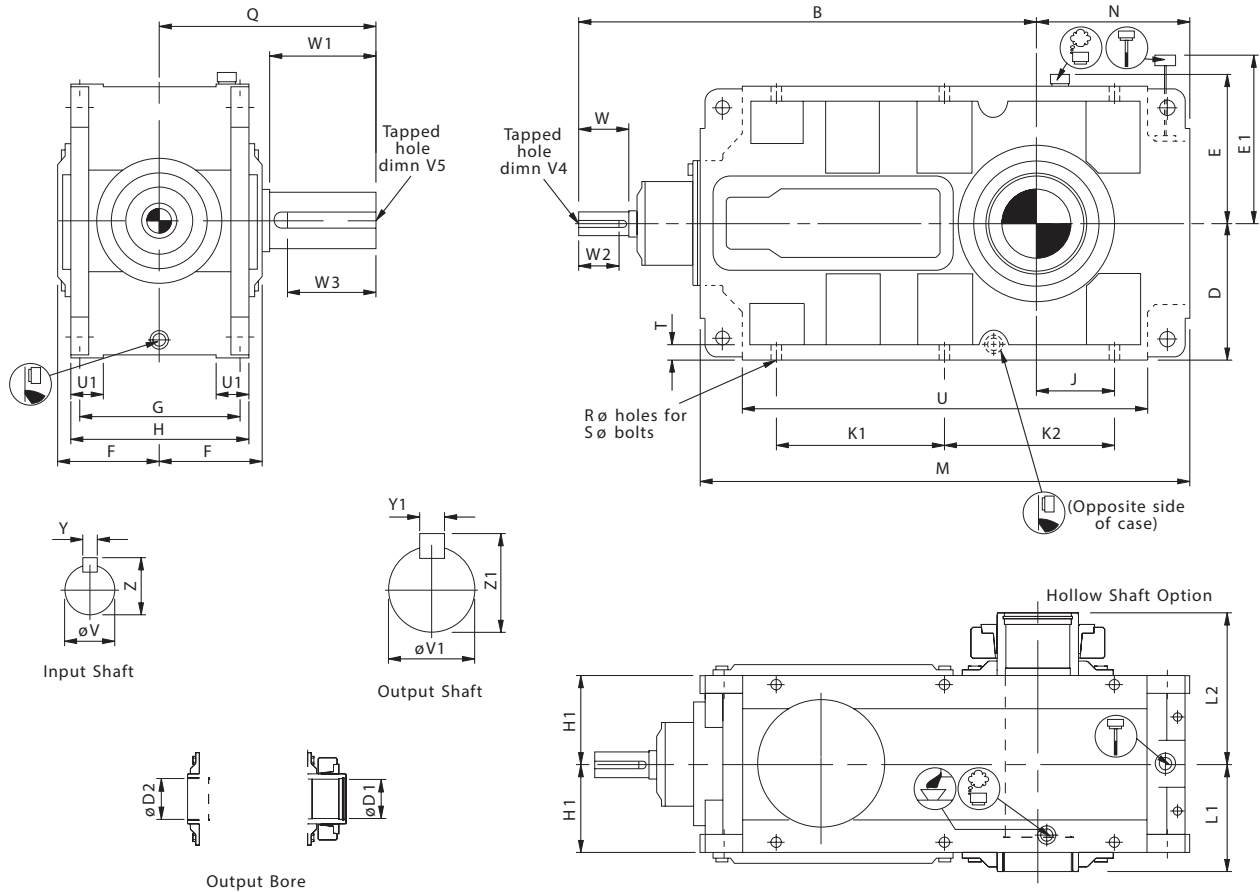

Unit Size	B	D	E	E1	F	G	H	H1	J	K1	K2	M	N	Q	R	S	T	U	U1
G16	37.99	11.81	13.19	20.28	8.86	12.99	14.96	7.48	8.86	15.16	0.00	41.73	14.57	18.11	1.10	6 x M24 x 80*	1.18	35.35	2.76
G17	40.16	11.81	13.19	20.28	8.86	12.99	14.96	7.48	6.69	15.16	0.00	41.73	12.40	18.90	1.10	6 x M24 x 80*	1.18	35.35	2.76
G18	49.80	15.16	16.54	27.95	11.42	17.32	19.69	9.84	6.02	20.47	13.78	48.82	13.31	23.62	1.30	6 x M30 x 100*	1.46	40.79	3.54
G19	52.36	15.16	16.54	27.95	11.42	17.32	19.69	9.84	8.66	19.69	19.69	54.09	16.02	25.59	1.30	6 x M30 x 100*	1.57	46.06	3.54
G21	65.35	18.31	19.96	29.53	13.39	20.87	23.62	11.81	8.86	27.36	18.90	65.16	18.31	27.56	1.54	6 x M36 x 100*	1.97	54.33	4.72
G22	66.93	18.31	19.96	29.53	13.39	20.87	23.62	11.81	9.65	29.33	19.29	67.52	19.09	28.74	1.54	6 x M36 x 100*	1.97	5.51	4.72

Unit Size	Input Shaft						Output Shaft						Output Bore			
	V	V4	W	W2	Y	Z	V1	V5	W1	W3	Y1	Z1	D1	D2	L1	L2
G16	1.500	5/8 UNF x 1.25	3.94	3.00	0.313	1.60	6.000	1.25 UNF x 2.5	9.06	8.75	1.50	6.66	4.92	5.12	9.06	12.80
G17	1.500	5/8 UNF x 1.25	3.94	3.00	0.313	1.60	6.750	1.25 UNF x 2.5	9.84	9.38	1.75	7.39	5.71	5.91	9.06	13.39
G18	1.875	5/8 UNF x 1.25	5.51	4.13	0.500	2.10	7.500	1.5 UNF x 3	11.81	11.38	1.75	8.15	6.30	6.69	11.81	16.14
G19	1.875	5/8 UNF x 1.25	5.51	4.13	0.500	2.10	8.250	1.5 UNF x 3	13.78	13.00	2.00	8.88	6.69	7.09	11.81	16.93
G21	3.000	3/4 UNF x 1.62	6.30	5.25	0.750	3.33	8.500	1.5 UNF x 3	13.78	13.00	2.00	9.13	8.27	8.66	13.78	19.69
G22	3.000	3/4 UNF x 1.62	6.30	5.25	0.750	3.33	9.250	1.5 UNF x 3	14.96	14.25	2.50	9.95	9.06	9.45	13.78	20.28

# SERIES G



## DIMENSIONS VERTICAL RIGHT ANGLE SHAFTS QUADRUPLE REDUCTION

DIMENSIONS IN mm

### G 4 0 R Quadruple Reduction Right Angle Units Vertical

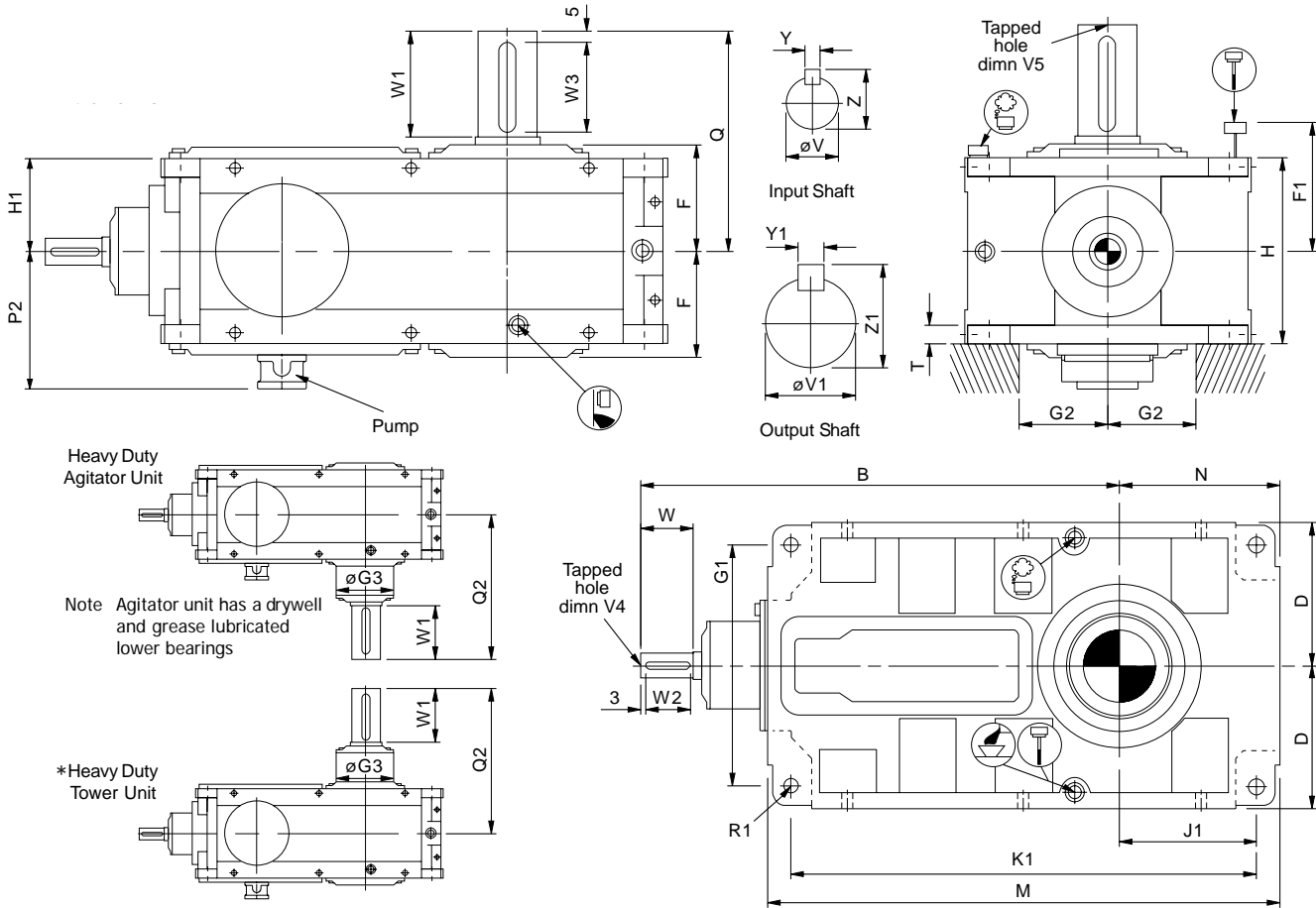

Unit Size	B	D	F	F1	G1	G2 (min)	G3	H	H1	J1	K1	M	N	P2	Q	Q2	R1	T
G16	965	300	225	515	506	175	300	380	190	325	970	1060	370	285	460	595	4 x Ø33	45
G17	1020	300	225	515	506	175	340	380	190	270	970	1060	315	285	480	615	4 x Ø33	45
G18	1265	385	290	700	656	205	370	500	250	281	1126	1240	338	345	600	760	4 x Ø40	55
G19	1330	385	290	700	656	205	400	500	250	350	1260	1374	407	345	650	815	4 x Ø40	55
G21	1660	465	340	750	790	255	500	600	300	395	1515	1655	465	400	700	925	4 x Ø48	70
G22	1700	465	340	750	790	265	*	600	300	415	1575	1715	485	400	730	*	4 x Ø48	70

Unit Size	Input Shaft ●						Output Shaft ●					
	V	V4	W	W2	Y	Z	V1	V5	W1	W3	Y1	Z1
G16	38 k6	M12 x32	100	90	10	41	145 m6	M42 x81	230	220	36	153
G17	38 k6	M12 x32	100	90	10	41	170 m6	M42 x81	250	240	40	179
G18	50 m6	M16 x36	140	130	14	53.5	190 m6	M42 x81	300	290	45	200
G19	50 m6	M16 x36	140	130	14	53.5	210 m6	M42 x81	350	340	50	221
G21	75 m6	M20 x43	160	150	20	79.5	220 m6	M42 x81	350	340	50	231
G22	75 m6	M20 x43	160	150	20	79.5	240 m6	M42 x81	380	340	56	252

\* = Contact Application Engineering

**DIMENSIONS IN inch**

**DIMENSIONS VERTICAL RIGHT ANGLE  
SHAFTS QUADRUPLE REDUCTION**

**G 40 R Quadruple Reduction Right Angle Units Vertical**

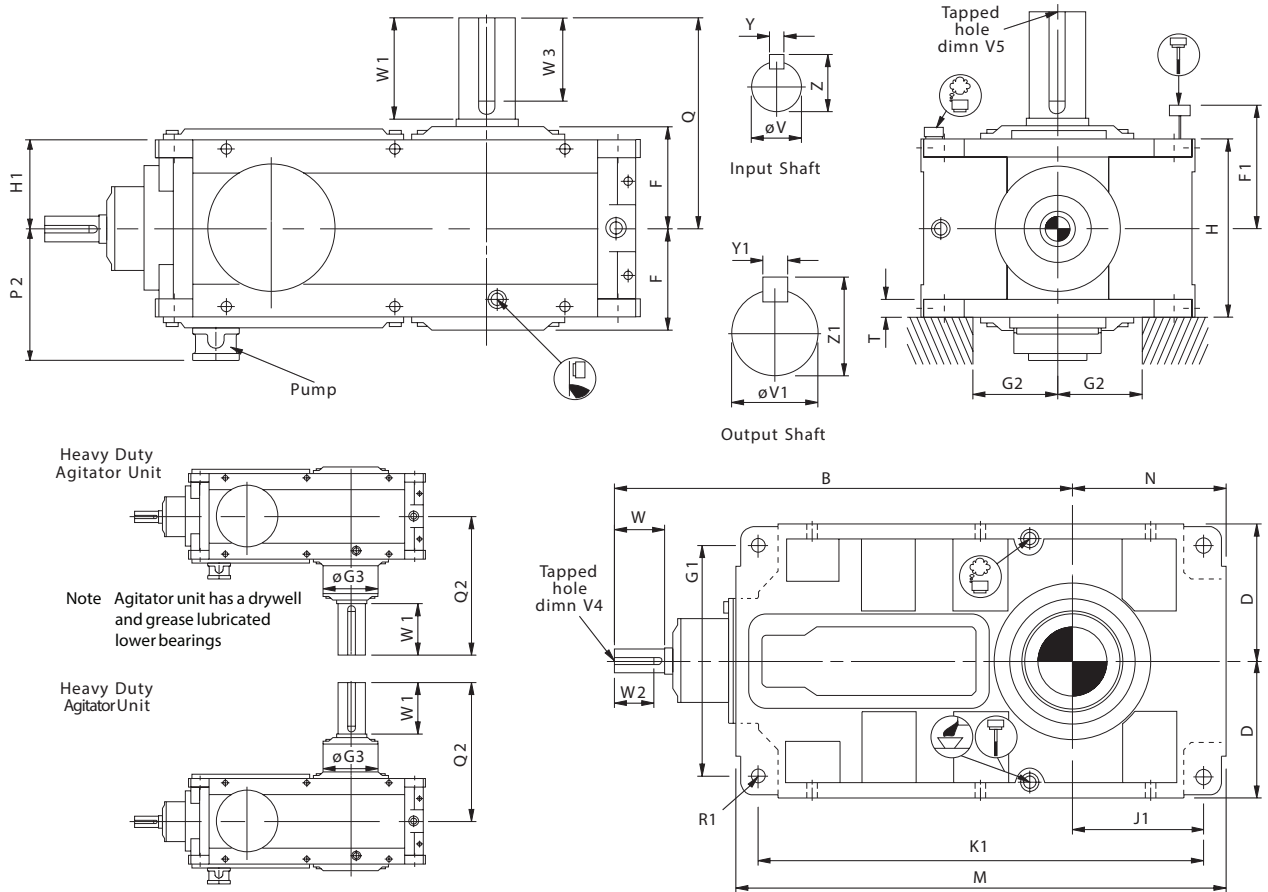

Unit Size	B	D	F	F1	G1	G2 (min)	G3	H	H1	J1	K1	M	N	P2	Q	Q2	R1	T
G16	37.99	11.81	8.86	20.28	19.92	6.89	11.81	14.96	7.48	12.80	38.19	41.73	14.57	11.22	18.11	23.43	4 x $\phi 33$	1.77
G17	40.16	11.81	8.86	20.28	19.92	6.89	13.39	14.96	7.48	10.63	38.19	41.73	12.40	11.22	18.90	24.21	4 x $\phi 33$	1.77
G18	49.80	15.16	11.42	27.56	25.83	8.07	14.57	19.69	9.84	11.06	44.33	48.82	13.31	13.58	23.62	29.92	4 x $\phi 40$	2.17
G19	52.36	15.16	11.42	27.56	25.83	8.07	15.75	19.69	9.84	13.78	49.61	54.09	16.02	13.58	25.59	32.09	4 x $\phi 40$	2.17
G21	65.35	18.31	13.39	29.53	31.10	10.04	19.69	23.62	11.81	15.55	59.65	65.16	18.31	15.75	27.56	36.42	4 x $\phi 48$	2.76
G22	66.93	18.31	13.39	29.53	31.10	10.43	*	23.62	11.81	16.34	62.01	67.52	19.09	15.75	28.74	*	4 x $\phi 48$	2.76

Unit Size	Input Shaft						Output Shaft					
	V	V4	W	W2	Y	Z	V1	V5	W1	W3	Y1	Z1
G16	1.500	5/8 UNF x 1.25	3.94	3.00	0.313	1.60	6.000	1.25 UNF x 2.5	9.06	8.75	1.50	6.66
G17	1.500	5/8 UNF x 1.25	3.94	3.00	0.313	1.60	6.750	1.25 UNF x 2.5	9.84	9.38	1.75	7.39
G18	1.875	5/8 UNF x 1.25	5.51	4.13	0.500	2.10	7.500	1.5 UNF x 3	11.81	11.38	1.75	8.15
G19	1.875	5/8 UNF x 1.25	5.51	4.13	0.500	2.10	8.250	1.5 UNF x 3	13.78	13.00	2.00	8.88
G21	3.000	3/4 UNF x 1.62	6.30	5.25	0.750	3.33	8.500	1.5 UNF x 3	13.78	13.00	2.00	9.13
G22	3.000	3/4 UNF x 1.62	6.30	5.25	0.750	3.33	9.250	1.5 UNF x 3	14.96	14.25	2.50	9.95

# SERIES G



DIMENSIONS IN mm

## DIMENSIONS HORIZONTAL 'J' TYPE RIGHT ANGLE SHAFTS TRIPLE REDUCTION

**G** 3 0 **B**

### Triple Reduction 'J' Type Right Angle Units Horizontal

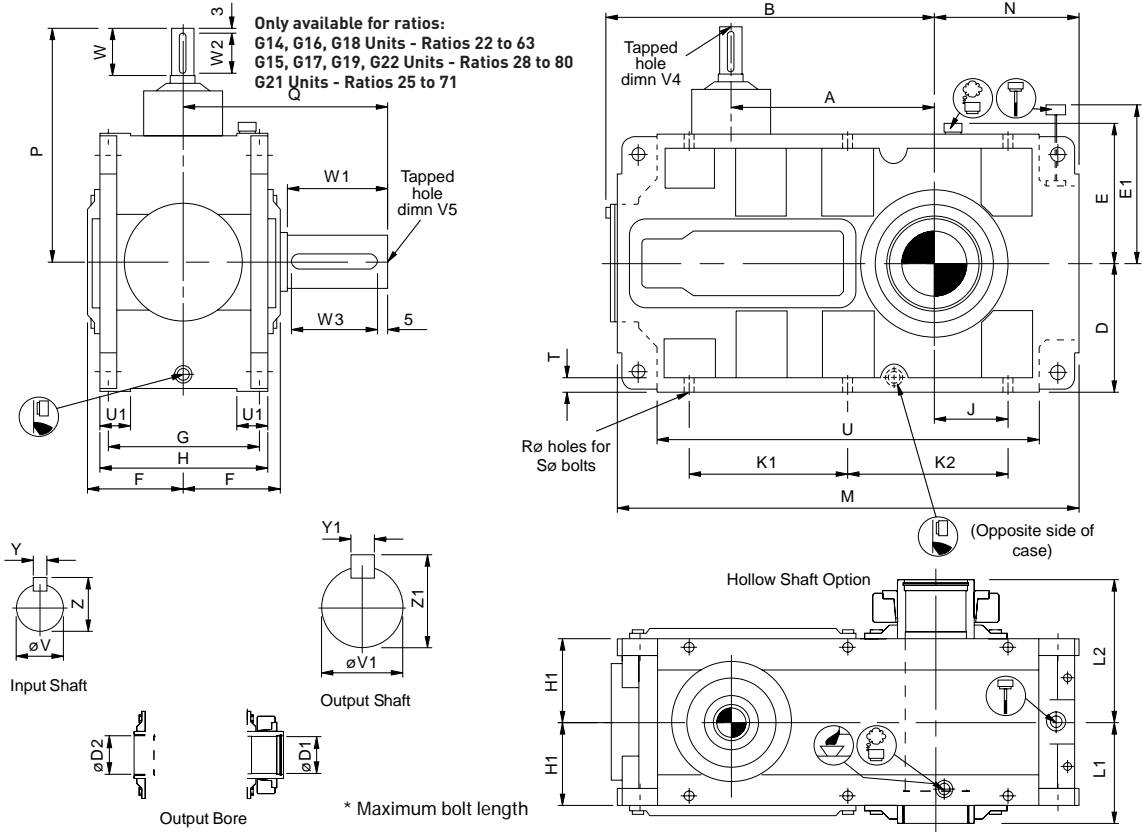

Unit Size	A	B	D	E	E1	F	G	H	H1	J	K1	K2	M	N	P	Q	R	S	T	U	U1
G14	325	554	230	250	370	177	265	300	150	170	285	820	295	395	360	18.5	6 x m16 x 60*	25	684	55	
G15	365	594	230	250	370	177	265	300	150	130	285	820	255	395	370	18.5	6 x m16 x 60*	25	684	55	
G16	430	728	300	335	515	225	330	380	190	225	385	1060	370	510	460	28	6 X m24 X 80*	30	898	70	
G17	485	783	300	335	515	225	330	380	190	170	385	1060	315	510	480	28	6 x m24 x 80*	30	898	70	
G18	570	953	385	420	710	290	440	500	250	153	520	350	1240	338	650	600	33	6 x m30 x 100*	37	1036	90
G19	635	1018	385	420	710	290	440	500	250	220	500	1374	407	650	650	33	6 x m30 x 100*	40	1170	90	
G21	765	1240	465	507	750	340	530	600	300	225	695	480	1655	465	865	700	39	6 x m36 x 100*	50	1380	120
G22	805	1280	465	507	750	340	530	600	300	245	745	490	1715	485	865	730	39	6 x m36 x 100*	50	1440	120

Unit Size	Input Shaft ●						Output Shaft ●						Output Bore ●			
	V	V4	W	W2	Y	Z	V1	V5	W1	W3	Y1	Z1	D1	D2	L1	L2
G14	38 k6	M12 x 32	100	90	10	41	110 m6	M30 x 63	180	170	28	116	95	100	180	255
G15	38 k6	M12 x 32	100	90	10	41	130 m6	M30 x 63	190	180	32	137	110	115	180	260
G16	50 k6	M16 x 36	140	130	14	53.5	145 m6	M42 x 81	230	220	36	153	125	130	230	325
G17	50 k6	M16 x 36	140	130	14	53.5	170 m6	M42 x 81	250	240	40	179	145	150	230	340
G18	75 m6	M20 x 43	160	150	20	79.5	190 m6	M42 x 81	300	290	45	200	160	170	300	410
G19	75 m6	M20 x 43	160	150	20	79.5	210 m6	M42 x 81	350	340	50	221	170	180	300	430
G21	100 m6	M24 x 52	210	200	28	106	220 m6	M42 x 81	350	340	50	231	210	220	350	500
G22	100 m6	M24 x 52	210	200	28	106	240 m6	M42 x 81	380	340	56	252	230	240	350	515

DIMENSIONS IN inch

**DIMENSIONS HORIZONTAL 'J' TYPE  
RIGHT ANGLE SHAFTS TRIPLE REDUCTION**

**G 3 0 B Triple Reduction 'J' Type Right Angle Units Horizontal**

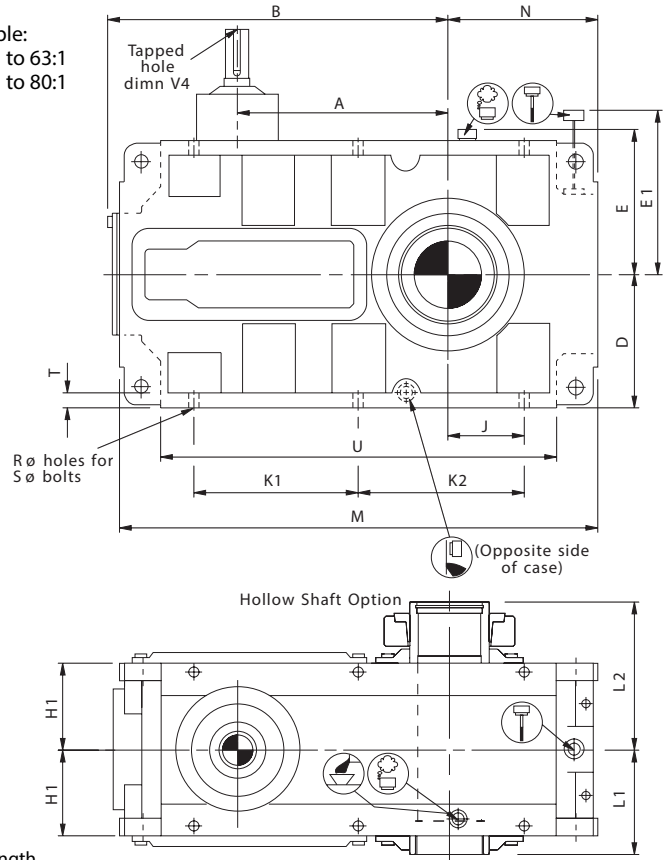
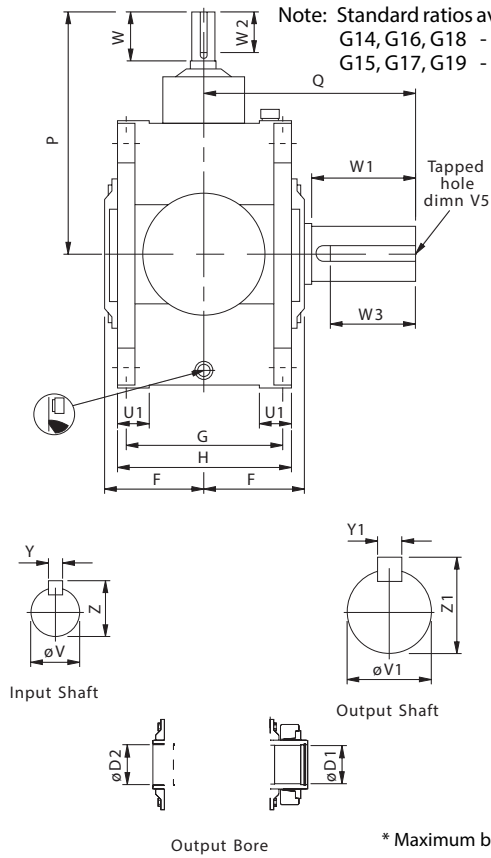

Output Bore

\* Maximum bolt length

Unit Size	A	B	D	E	E1	F	G	H	H1	J	K1	K2	M	N	P	Q	R	S	T	U	U1
G14	12.80	21.81	9.06	9.84	14.57	6.97	10.43	11.81	5.91	6.69	11.22	0.00	32.28	11.61	15.55	14.17	0.73	6 x m16 x 60*	0.98	26.93	2.17
G15	14.37	23.39	9.06	9.84	14.57	6.97	10.43	11.81	5.91	5.12	11.22	0.00	32.28	10.04	15.55	14.57	0.73	6 x m16 x 60*	0.98	26.93	2.17
G16	16.93	28.66	11.81	13.19	20.28	8.86	12.99	14.96	7.48	8.86	15.16	0.00	41.73	14.57	20.08	18.11	1.10	6 X m24 X 80*	1.18	35.35	2.76
G17	19.09	30.83	11.81	13.19	20.28	8.86	12.99	14.96	7.48	6.69	15.16	0.00	41.73	12.40	20.08	18.90	1.10	6 x m24 x 80*	1.18	35.35	2.76
G18	22.44	37.52	15.16	16.54	27.95	11.42	17.32	19.69	9.84	6.02	20.47	13.78	48.82	13.31	25.59	23.62	1.30	6 x m30 x 100*	1.46	40.79	3.54
G19	25.00	40.08	15.16	16.54	27.95	11.42	17.32	19.69	9.84	8.66	19.69	0.00	54.09	16.02	25.59	25.59	1.30	6 x m30 x 100*	1.57	46.06	3.54
G21	30.12	48.82	18.31	19.96	29.53	13.39	20.87	23.62	11.81	8.86	27.36	18.90	65.16	18.31	34.06	27.56	1.54	6 x m36 x 100*	1.97	54.33	4.72
G22	31.69	50.39	18.31	19.96	29.53	13.39	20.87	23.62	11.81	9.45	28.94	19.49	67.52	19.09	34.06	28.74	1.54	6 x m36 x 100*	1.97	56.69	4.72

Unit Size	Input Shaft						Output Shaft						Output Bore			
	V	V4	W	W2	Y	Z	V1	V5	W1	W3	Y1	Z1	D1	D2	L1	L2
G14	1.500	5/8 UNF x 1.25	3.94	3.00	0.313	1.60	4.500	1 UNF x 2	7.09	6.50	1.00	4.94	3.74	3.94	7.09	10.04
G15	1.500	5/8 UNF x 1.25	3.94	3.00	0.313	1.60	5.000	1 UNF x 2	7.48	7.13	1.25	5.55	4.33	4.53	7.09	10.24
G16	1.875	5/8 UNF x 1.25	5.51	4.13	0.500	2.10	6.000	1.25 UNF x 2.5	9.06	8.75	1.50	6.66	4.92	5.12	9.06	12.80
G17	1.875	5/8 UNF x 1.25	5.51	4.13	0.500	2.10	6.750	1.25 UNF x 2.5	9.84	9.38	1.75	7.39	5.71	5.91	9.06	13.39
G18	3.000	3/4 UNF x 1.62	6.30	5.25	0.750	3.33	7.500	1.5 UNF x 3	11.81	11.38	1.75	8.15	6.30	6.69	11.81	16.14
G19	3.000	3/4 UNF x 1.62	6.30	5.25	0.750	3.33	8.250	1.5 UNF x 3	13.78	13.00	2.00	8.88	6.69	7.09	11.81	16.93
G21	4.000	1 UNF x 2	8.27	7.50	1.000	4.44	8.500	1.5 UNF x 3	13.78	13.00	2.00	9.13	8.27	8.66	13.78	19.69
G22	4.000	1 UNF x 2	8.27	7.50	1.000	4.44	9.250	1.5 UNF x 3	14.96	14.25	2.50	9.95	9.06	9.45	13.78	20.28

DIMENSIONS IN mm

## DIMENSIONS VERTICAL 'J' TYPE RIGHT ANGLE SHAFTS TRIPLE REDUCTION

### G 3 0 R Triple Reduction 'J' Type Right Angle Units Vertical

Only available for ratios:  
 G14, G16, G18 Units - Ratios 22 to 63  
 G15, G17, G19, G22 Units - Ratios 28 to 80  
 G21 Units - Ratios 25 to 71

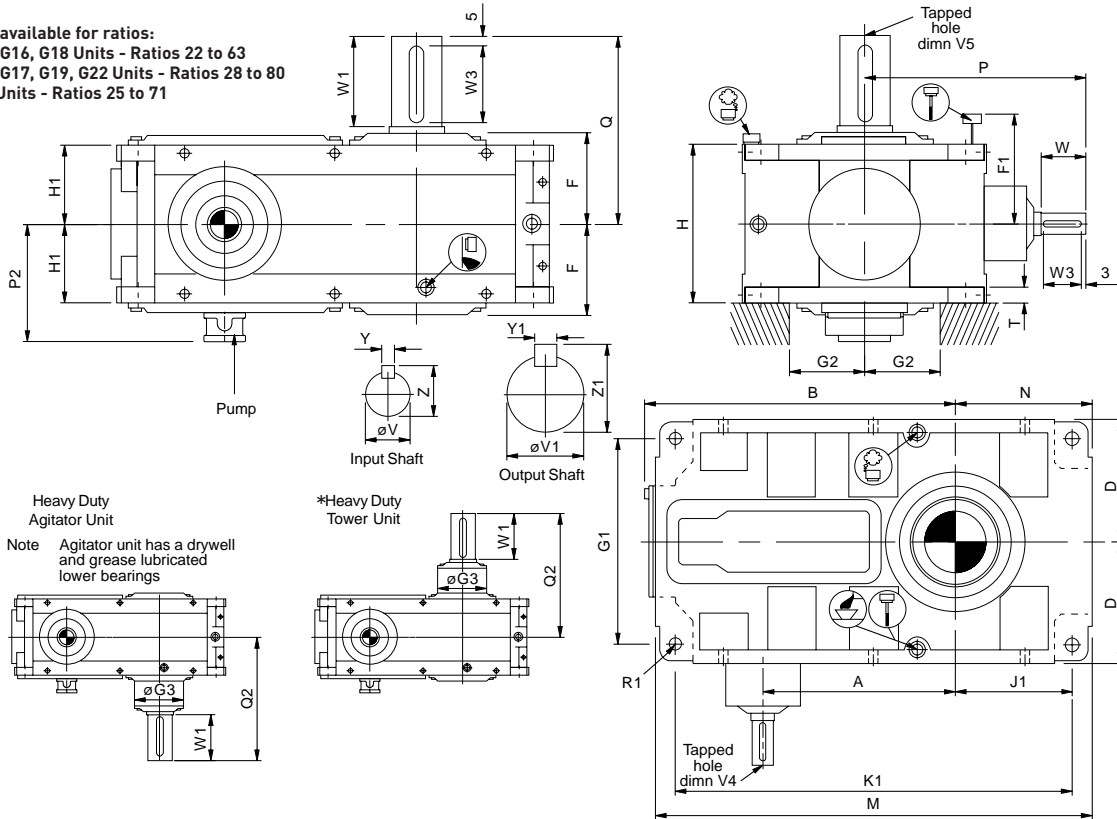

Unit Size	A	B	D	F	F1	G1	G2 (min)	G3	H	H1	J1	K1	M	N	P	P2	Q	Q2	R1	T
G14	325	554	230	177	390	390	135	230	300	150	260	750	820	295	395	236	360	475	4 x $\phi 24$	30
G15	365	594	230	177	390	390	135	260	300	150	220	750	820	255	395	236	370	495	4 x $\phi 24$	30
G16	430	728	300	225	515	506	175	300	380	190	325	970	1060	370	510	285	460	595	4 x $\phi 33$	45
G17	485	783	300	225	515	506	175	340	380	190	270	970	1060	315	510	285	480	615	4 x $\phi 33$	45
G18	570	953	385	290	700	656	205	370	500	250	281	1126	1240	338	650	345	600	760	4 x $\phi 40$	55
G19	635	1018	385	290	700	656	205	400	500	250	350	1260	1374	407	650	345	650	815	4 x $\phi 40$	55
G21	765	1240	465	340	750	790	255	500	600	300	395	1515	1655	465	865	400	700	925	4 x $\phi 48$	70
G22	805	1280	465	340	750	790	265	*	600	300	415	1575	1715	485	865	400	730	*	4 x $\phi 48$	70

Unit Size	Input Shaft ●						Output Shaft ●					
	V	V4	W	W2	Y	Z	V1	V5	W1	W3	Y1	Z1
G14	38 k6	M12 x 32	100	90	10	41	110 m6	M30 x 63	180	170	28	116
G15	38 k6	M12 x 32	100	90	10	41	130 M6	M30 x 63	190	180	32	137
G16	50 m6	M16 x 36	140	130	14	53.5	145 M6	M42 x 81	230	220	36	153
G17	50 m6	M16 x 36	140	130	14	53.5	170 M6	M42 x 81	250	240	40	179
G18	75 m6	M20 x 43	160	150	20	79.5	190 M6	M42 x 81	300	290	45	200
G19	75 m6	M20 x 43	160	150	20	79.5	210 M6	M42 x 81	350	340	50	221
G21	100 m6	M24 x 52	210	200	29	106	220 M6	M42 x 81	350	340	50	231
G22	100 m6	M24 x 52	210	200	28	106	240 M6	M42 x 81	380	340	56	252

\* = Contact Application Engineering

DIMENSIONS IN inch

**DIMENSIONS VERTICAL 'J' TYPE  
RIGHT ANGLE SHAFTS TRIPLE REDUCTION**

**G 3 0 R Triple Reduction 'J' Type Right Angle Units Vertical**

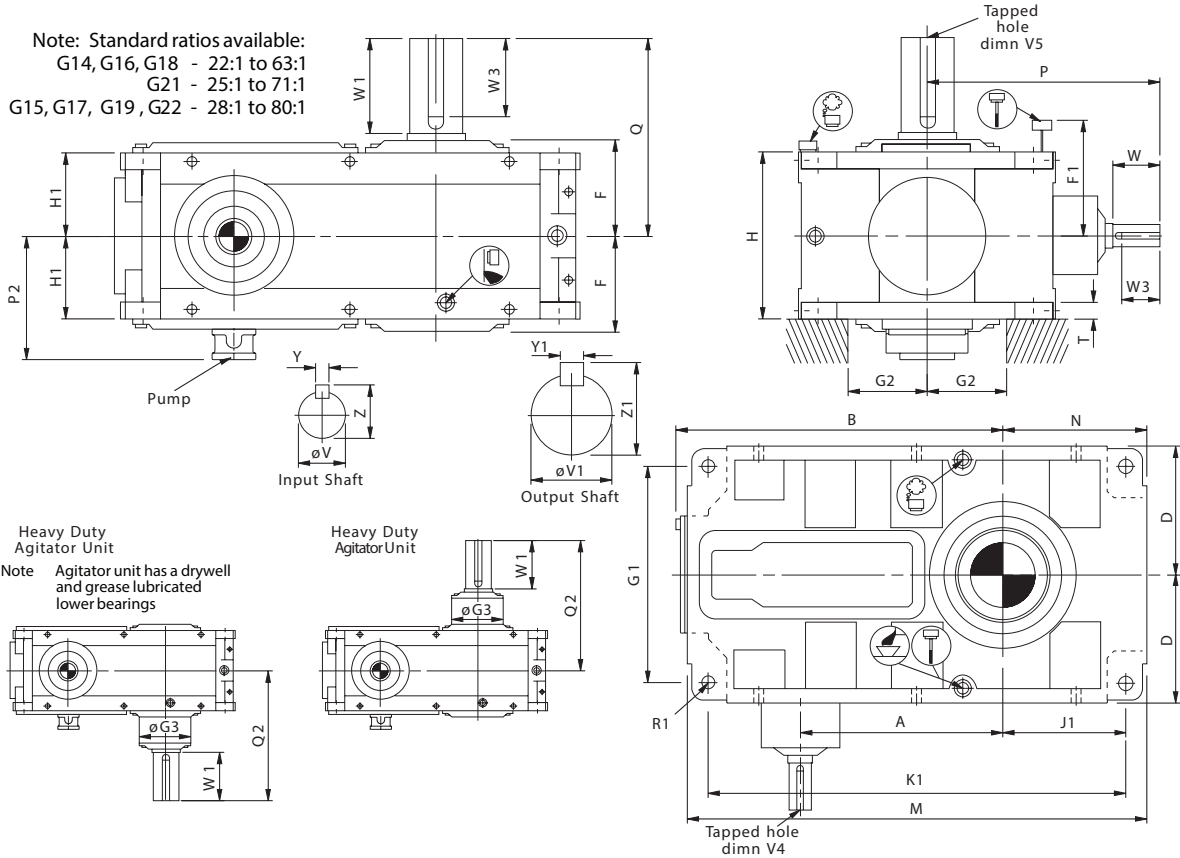

Unit Size	A	B	D	F	F1	G1	G2 (min)	G3	H	H1	J1	K1	M	N	P	P2	Q	Q2	R1	T
G14	12.80	21.81	9.06	6.97	15.35	15.35	5.31	9.06	11.81	5.91	10.24	29.53	32.28	11.61	15.55	9.29	14.17	18.70	4 x Ø24	1.18
G15	14.37	23.39	9.06	6.97	15.35	15.35	5.31	10.24	11.81	5.91	8.66	29.53	32.28	10.04	15.55	9.29	14.57	19.49	4 x Ø24	1.18
G16	16.93	28.66	11.81	8.86	20.28	19.92	6.89	11.81	14.96	7.48	12.80	38.19	41.73	14.57	20.08	11.22	18.11	23.43	4 x Ø33	1.77
G17	19.09	30.83	11.81	8.86	20.28	19.92	6.89	13.39	14.96	7.48	10.63	38.19	41.73	12.40	20.08	11.22	18.90	24.21	4 x Ø33	1.77
G18	22.44	37.52	15.16	11.42	27.56	25.83	8.07	14.57	19.69	9.84	11.06	44.33	48.82	13.31	25.59	13.58	23.62	29.92	4 x Ø40	2.17
G19	25.00	40.08	15.16	11.42	27.56	25.83	8.07	15.75	19.69	9.84	13.78	49.61	54.09	16.02	25.59	13.58	25.59	32.09	4 x Ø40	2.17
G21	30.12	64.17	18.31	13.39	29.53	31.10	10.04	19.69	23.62	11.81	15.55	59.65	65.16	18.31	34.06	15.75	27.56	36.42	4 x Ø48	2.76
G22	31.69	50.39	18.31	13.39	29.53	31.10	10.43	*	23.62	11.81	16.34	62.01	67.52	19.09	34.06	15.75	28.74	*	4 x Ø48	2.76

Unit Size	Input Shaft						Output Shaft					
	V	V4	W	W2	Y	Z	V1	V5	W1	W3	Y1	Z1
G14	1.500	5/8 UNF x 1.25	3.94	3.00	0.313	1.60	4.500	1 UNF x 2	7.09	6.50	1.00	4.94
G15	1.500	5/8 UNF x 1.25	3.94	3.00	0.313	1.60	5.000	1 UNF x 2	7.48	7.13	1.25	5.55
G16	1.875	5/8 UNF x 1.25	5.51	4.13	0.500	2.10	6.000	1.25 UNF x 2.5	9.06	8.75	1.50	6.66
G17	1.875	5/8 UNF x 1.25	5.51	4.13	0.500	2.10	6.750	1.25 UNF x 2.5	9.84	9.38	1.75	7.39
G18	3.000	3/4 UNF x 1.62	6.30	5.25	0.750	3.33	7.500	1.5 UNF x 3	11.81	11.38	1.75	8.15
G19	3.000	3/4 UNF x 1.62	6.30	5.25	0.750	3.33	8.250	1.5 UNF x 3	13.78	13.00	2.00	8.88
G21	4.000	1 UNF x 2	8.27	7.50	1.000	4.44	8.500	1.5 UNF x 3	13.78	13.00	2.00	9.13
G22	4.000	1 UNF x 2	8.27	7.50	1.000	4.44	9.250	1.5 UNF x 3	14.26	14.25	2.50	9.95

# SERIES G

## FAN COOLING DIMENSIONS RIGHT ANGLE SHAFTS

### Right Angle Shaft Units with Mechanical Fans

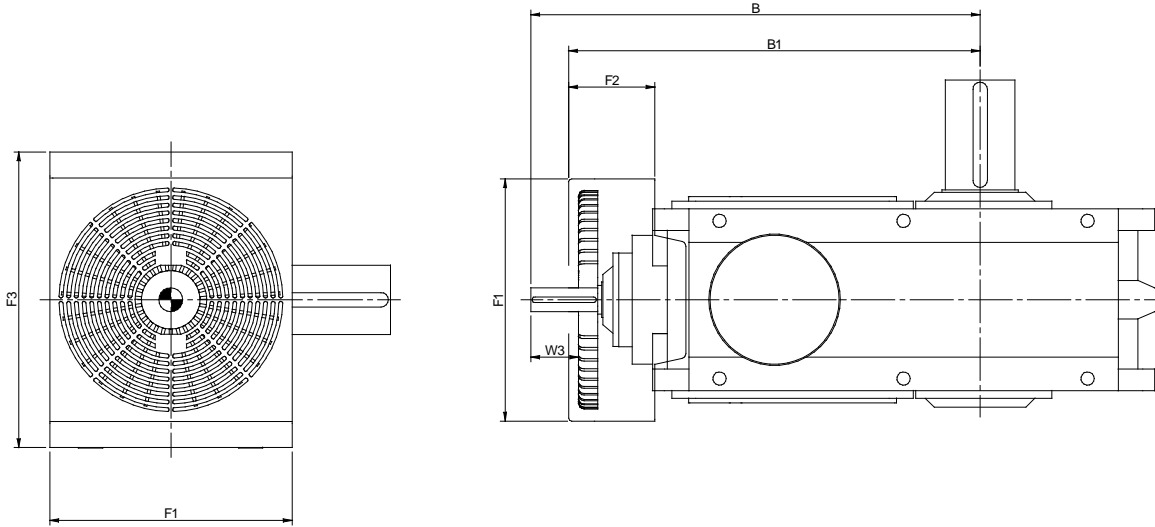

### Triple Reduction Only

Unit Size	B	B1	F1	F2	F3	W3 (useable shaft extension)
G14	28.35	26.38	15.24	5.51	18.78	2.76
G15	29.92	27.95	15.24	5.51	18.78	2.76
G16	37.01	33.86	19.96	7.09	24.37	3.94
G17	39.17	36.02	19.96	7.09	24.37	3.94
G18	48.03	44.61	24.61	9.06	31.10	4.13
G19	50.59	47.17	24.61	9.06	31.10	4.13
G21	64.17	58.90	30.00	11.69	37.56	6.10
G22	65.75	60.47	30.00	11.69	37.56	6.10

# SERIES G

## HOLLOW OUTPUT SHAFT WITH SHRINK DISK



The gear unit is fitted with a 'shrink disk' device located on the hollow output shaft to provide a positive outer locking connection between gear unit and driven shaft. The 'shrink disk' is a friction device, without keys, which exerts an external clamping force on the hollow output shaft, thus establishing a mechanical shrink fit between the gear unit hollow shaft and driven shaft. 'Shrink disk' capacities have ample margins in dealing with transmitted torques and external loading imposed on gear units.

### WORKING PRINCIPLE

The 'shrink disk' consists of a locking collar, a tapered inner ring and locking screws. By tightening the locking screws, the locking collar and tapered inner ring are pulled together, exerting radial forces on the inner ring, thus creating a positive friction connection between hollow shaft and driven shaft.

As the tapered surfaces of locking collar and inner ring are lubricated with Molykote 321R or similar and the taper angle is not self locking, locking collar will not seize on the inner ring and can be released easily when removal is necessary.

When the shrink disk is clamped in position the high contact pressures between tapered surfaces and screw heads and their seatings ensure hermetic sealing and eliminate the possibility of fretting corrosion.

Unit Size	CUSTOMERS SHAFT								SHRINK DISK						
	ød1	ød2	ød3	ød4	I	I1	I2	K	Type	B	øD	øG	H	M	Torque Ta (lb-ft)
14	3.7402 3.7393	3.9370 3.9361	3.72	4.53	16.26	2.17	1.97	1" UNF x2"	HSD 120-81-95	0.87	4.72	7.76	2.09	M12	90
15	4.3307 4.3087	4.5276 4.5267	4.31	5.12	16.46	2.36	2.36	1" UNF x2"	HSD 140-81-110	0.87	5.51	9.06	2.28	M14	140
16	4.9213 4.9203	5.1181 5.1171	4.90	5.79	20.87	2.76	2.76	1" UNF x2"	HSD 160-81-125	1.10	6.30	11.42	2.68	M16	220
17	5.7087 5.7077	5.9055 5.9045	5.69	6.57	21.46	3.54	3.54	1 1/4" UNF x 2.36"	HSD 180-81-145	1.10	7.09	12.60	3.35	M16	220
18	6.2992 6.2983	6.6929 6.6914	6.28	7.28	26.97	3.54	3.54	1 1/4" UNF x 2.36"	HSD 200-81-160	1.18	7.87	13.39	3.35	M16	220
19	6.6923 6.6914	7.0861 7.0851	6.67	7.68	27.76	4.13	4.13	1 1/4" UNF x 2.36"	HSD 220-81-170	1.18	8.66	14.57	4.06	M20	420
21	8.2671 8.2659	8.6608 8.6596	8.25	8.86	32.28	5.12	4.13	1 1/4" UNF x 2.36"	HSD 260-81-210	1.18	10.24	16.93	4.69	M20	420
22	9.0545 9.0533	9.4482 9.4470	9.04	9.25	32.87	5.71	4.13	1 1/4" UNF x 2.36"	HSD 280-81-230	1.18	11.02	18.11	5.20	M20	420

Unit Size	HOLLOW SHAFT							END PLATE						
	ød1	ød2	ød3	L	L1	L2	L3	C	C1	ød5	ød6	øK1	P	Circlip
14	3.7415 3.7402	3.940 3.937	3.780	16.339	7.087	10.039	10.866	0.787	0.393 0.385	3.927 3.917	3.07	1.02	2.17	1/2" UNF D1300-1000
15	4.3321 4.3307	4.531 4.528	4.370	16.535	7.087	10.236	10.866	0.787	0.393 0.385	4.518 4.508	3.54	1.02	2.56	1/2" UNF D1300-1150
16	4.9228 4.9213	5.122 5.118	4.961	20.984	9.055	12.795	13.701	0.984	0.472 0.464	5.108 5.098	4.06	1.02	2.76	5/8" UNF D1300-1300
17	5.7102 5.7087	5.909 5.906	5.787	21.575	9.055	13.386	13.701	0.984	0.472 0.464	5.896 5.886	4.72	1.30	3.35	5/8" UNF D1300-1500
18	6.3008 6.2992	6.697 6.693	6.378	27.087	11.811	16.142	17.402	0.984	0.472 0.464	6.683 6.673	5.31	1.30	3.94	5/8" UNF D1300-1700
19	6.6945 6.6929	7.091 7.087	6.772	27.874	11.811	16.929	17.402	0.984	0.472 0.464	7.274 7.264	5.91	1.30	4.33	5/8" UNF D1300-1850
21	8.2695 8.2677	8.665 8.661	8.346	32.441	13.780	19.685	20.079	1.102	0.551 0.543	8.652 8.642	6.69	1.30	5.12	3/4" UNF D1300-2200
22	9.0569 9.0551	9.452 9.448	9.134	33.031	13.780	20.276	21.063	1.102	0.551 0.543	9.439 9.433	7.48	1.30	5.91	3/4" UNF D1300-2400

Customers Shaft

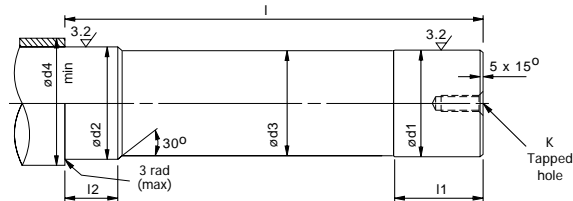

Hollow Shaft and Shrink Disc

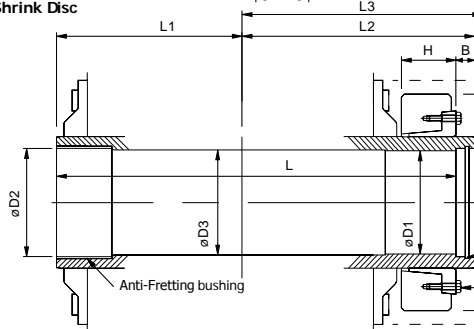

End Plate (if required)

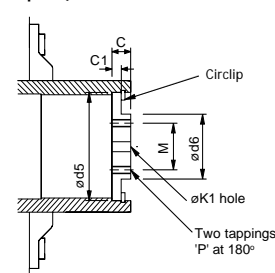

# SERIES G

## KEYED SLEEVES

Customers Shaft

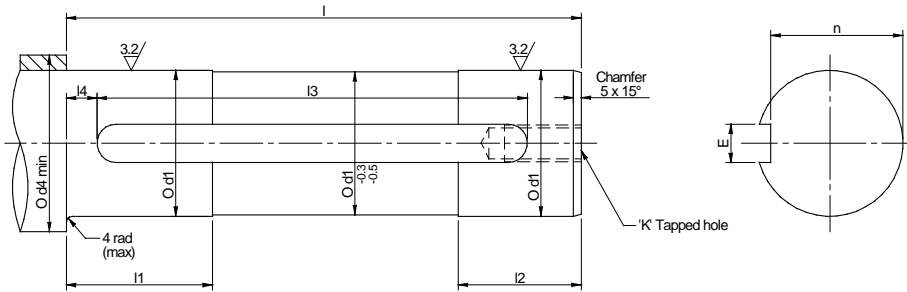

Hollow Shaft

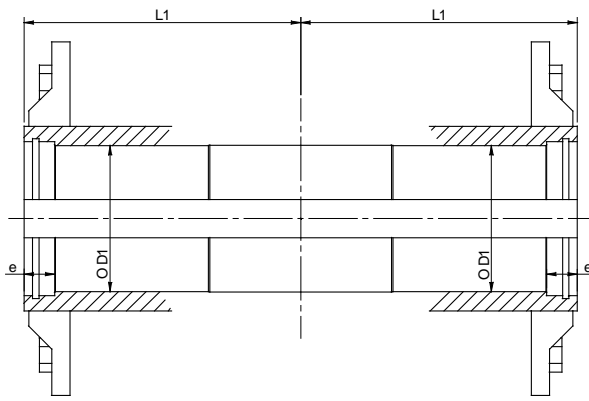

End Plate (If required)

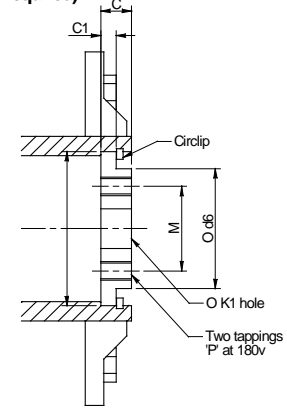

### Column 10 Entry

Inch



Metric



Consult Application Engineering for dimensions of metric sleeves

G

UNIT SIZE	CUSTOMERS SHAFT										
	Ød1	Ød4	l	l1	l2	l3 [min]	l4	m	n	k	Key Section (not supplied)
14	3.7500" 3.7491"	4.50"	13.19"	3.75"	3.12"	11.00"	0.75"	0.877" 0.875"	3.261" 3.246"	1" UNF 2.00" deep	0.875" square
15	4.3750" 4.3741"	5.12"	13.19"	4.12"	3.50"	11.00"	0.75"	1.002" 1.000"	3.817" 3.802"	1" UNF 2.00" deep	1.00" square
16	5.0000" 4.9990"	5.75"	16.91*	4.75"	3.88"	14.12"	1.00"	1.252" 1.250"	4.296" 4.281"	1" UNF 2.00" deep	1.25" square
17	5.7500" 5.7490"	6.56"	16.91"	5.12"	4.38"	14.12"	1.00"	1.502" 1.500"	4.900" 4.885"	1.1/4" UNF 2.50" deep	1.50" square
18	6.2500" 6.2490"	7.56"	22.44"	5.75"	5.00"	20.50"	1.00"	1.502" 1.500"	5.409" 5.394"	1.1/4" UNF 2.50" deep	1.50" square
19	6.9994" 6.9984"	8.12"	22.44"	6.12"	5.38"	20.50"	1.00"	1.752" 1.750"	6.139" 6.124"	1.1/4" UNF 2.50" deep	1.75" x 1.50"
21	8.2494" 8.2482"	8.88"	26.38"	6.50"	5.75"	24"	1.12"	2.002" 2.000"	7.377" 7.362"	1.1/4" UNF 2.50" deep	2.00" x 1.50"
22	8.9994" 8.9982"	9.84"	26.38"	6.88"	6.12"	24"	1.12"	2.002" 2.000"	8.137" 8.122"	1.1/4" UNF 2.50" deep	2.00" x 1.50"

UNIT SIZE	HOLLOW SHAFT			END PLATE							
	ØD1	e	L1	C	C1	Ød5	Ød6	ØK1	M crs	P	Circlip
14	3.7514" 3.7500"	0.750"	7.09"	0.75"	0.375" 0.370"	4.000" 3.990"	3.0"	1.06"	2.12"	1/2" UNF	N1300-0400
15	4.3764" 4.3750"	0.750"	7.09"	0.75"	0.375" 0.370"	4.625" 4.615"	3.5"	1.06"	2.50"	1/2" UNF	N1300-0462
16	5.0016" 5.0000"	0.875"	9.06"	1.00"	0.500" 0.495"	5.250" 5.240"	4.0"	1.06"	2.75"	5/8" UNF	N1300-0500
17	5.7516" 5.7500"	0.875"	9.06"	1.00"	0.500" 0.495"	6.000" 5.990"	4.75"	1.38"	3.38"	5/8" UNF	N1300-0575
18	6.2516" 6.2500"	0.875"	11.81"	1.00"	0.500" 0.495"	6.750" 6.740"	5.31"	1.38"	4.00"	5/8" UNF	N1300-0625
19	7.0016" 7.0000"	0.875"	11.81"	1.00"	0.500" 0.495"	7.250" 7.240"	5.88"	1.38"	4.38"	5/8" UNF	N1300-0700
21	8.2518" 8.2500"	1.000"	13.78"	1.12"	0.563" 0.558"	8.750" 8.740"	6.75"	1.38"	5.12"	3/4" UNF	N1300-0825
22	9.0018" 9.0000"	1.000"	13.78"	1.12"	0.563" 0.558"	9.500" 9.490"	7.50"	1.38"	5.88"	3/4" UNF	N1300-0900

# SERIES G

## COOLING COIL CONNECTIONS

Cooling coils can be fitted to all unit types and handings.

Cooling coil connections for water inlet and outlet pipes are  $\varnothing 0.47''$  ( $\varnothing 12$  mm) on all sizes.

The protruding cooling coil pipe can be connected to customers pipe work via a suitable straight coupling.

Water supply: Cooling coils are suitable for fresh, brackish or sea water with flow in either direction. Connections are therefore interchangeable.

For best performance, the water supply should be at  $50^{\circ}\text{F}$  /  $54^{\circ}\text{F}$  temperature and at a flow rate of 1.3 gallons per minute.

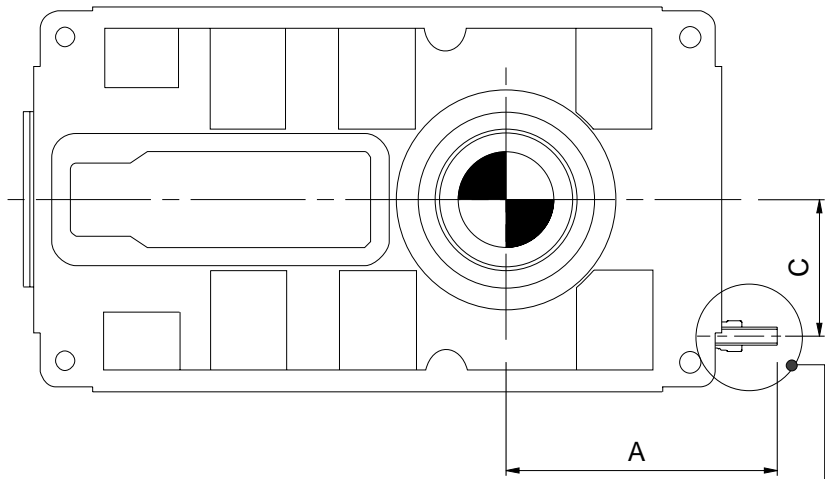
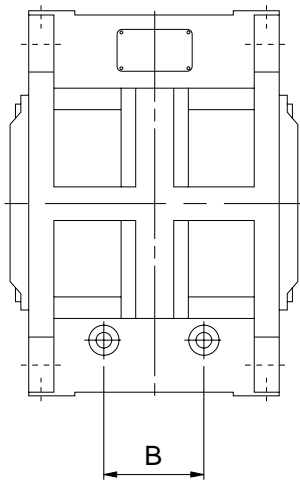

SIZE OF UNIT	A	B	C
14	12.20	4.72	6.42
15	10.63	4.72	6.42
16	14.57	5.91	8.66
17	12.40	5.91	8.66
18	12.40	7.87	11.22
19	15.16	7.87	11.22
21	15.75	7.87	13.98
22	16.54	7.87	13.98

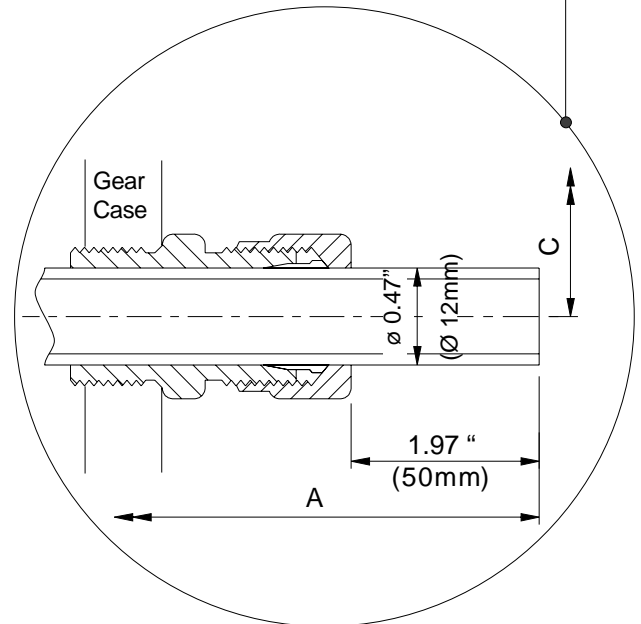

# SERIES G

## BACKSTOPS

Externally mounted Backstops can be fitted to all Series G gear units, when required to operate in non-reversing drives. They are located on the helical pinion shaft and have adequate capacities to deal with full rated torques. All backstops are centrifugal lift off type. Changing the direction of locking rotation is a simple operation.

### Parallel Shaft Units

Column 16 entry, shaft rotation shown

3 Stage

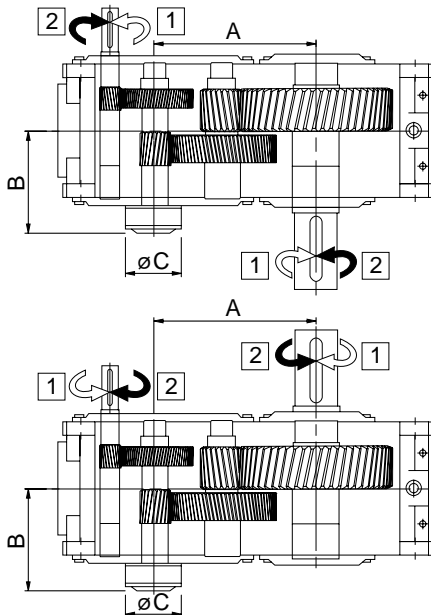

4 Stage

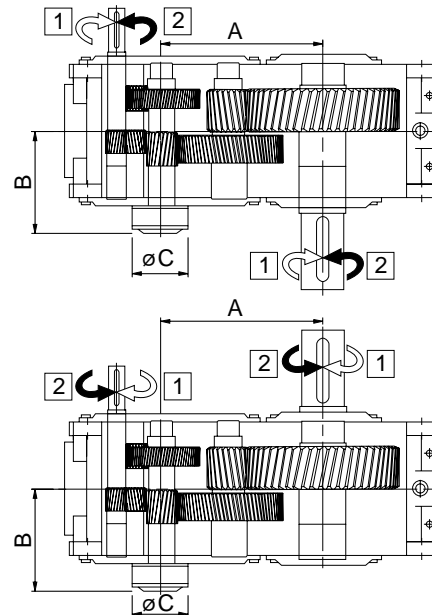

### Right Angle Shaft Units

Column 16 entry, shaft rotation shown

For right angle units, if backstop position is required at opposite side of unit to output shaft, column 16 entry must be 3 or 4 (see page 11)

3 Stage

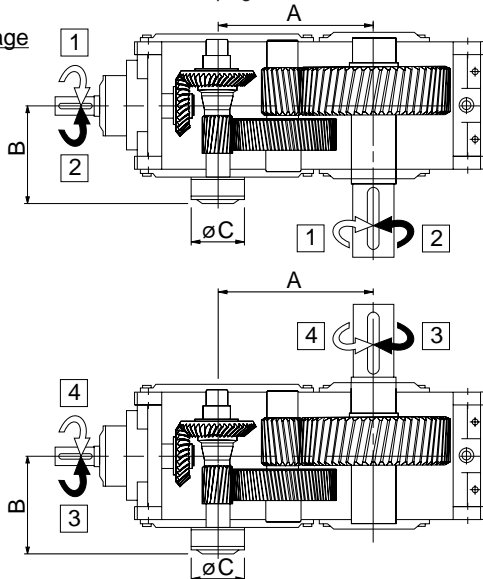

4 Stage

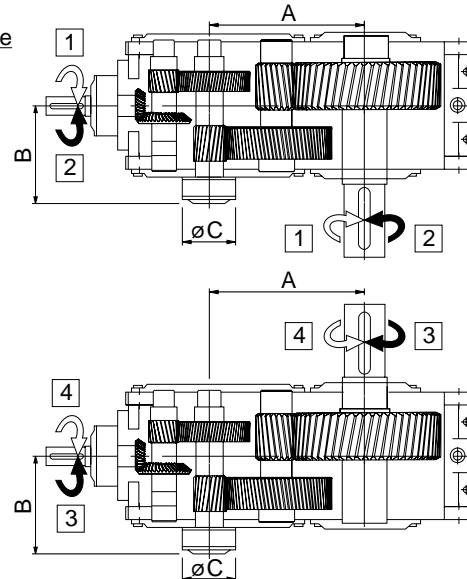

Unit Size	A	B	øC	Backstop
G14	12.80	10.83	6.89	85-40
G15	14.37			
G16	16.93	13.39	8.27	120-50
G17	19.09	17.05	11.42	170-63
G18	22.44			
G19	25.00	19.69	12.20	200-63
G21	30.12			
G22	31.69			

Note: Torque limiting backstops with controllable tension release can be fitted to all Series G units. (For details consult our Application Engineers).

# SERIES G

## TORQUE ARM

Torque arms are available for all shaft mounted units with parallel or right angle shafts. They are supplied as optional extras and are secured to gear cases as shown below.

Torque arms must be secured to the chassis structure in a flexible mounting as indicated.

Shaft mounted units are designed to operate in the horizontal position. Reference must be made to our Application Engineers, with details, where units are required to operate in an inclined position.

### SHAFT MOUNTED UNITS FOR HIGH INERTIA DRIVE

When used on Traverse drives with high inertia driven loads, e.g. crane drives (slewing, long travel and cross travel) bogie drives and selected high inertia load roller table drives, it is recommended that shaft mounted units should be fitted with shock absorbing Torque Arms. Consult our Application Engineers with specific application details.

It is recommended that the torque arm is fitted on the side of the unit adjacent to the driven machine.

The torque arm must be flexibly mounted to the chassis structure

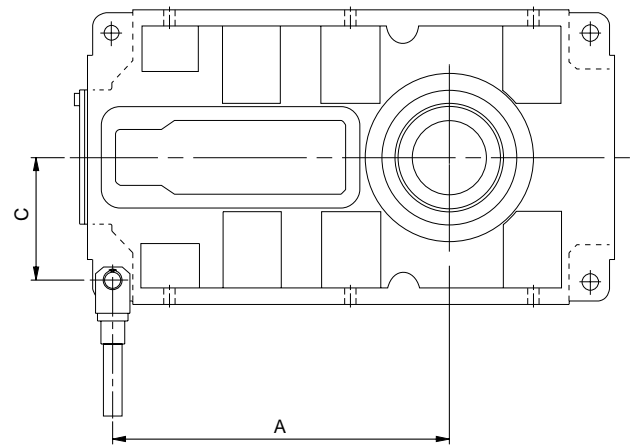
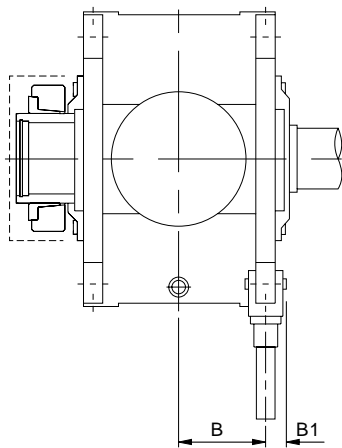
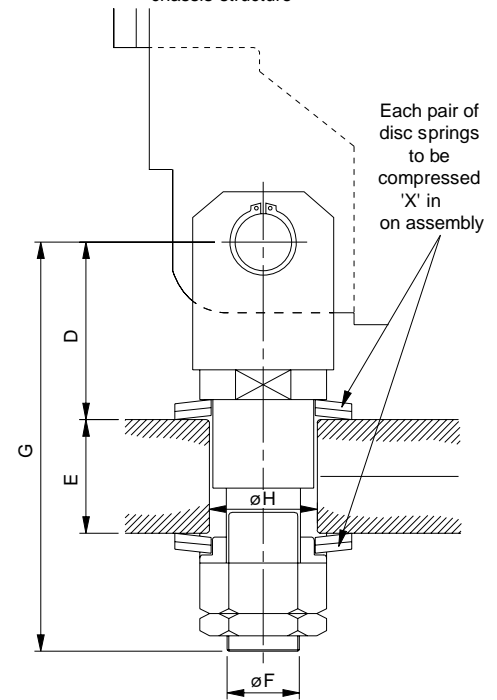

SIZE OF UNIT	A	B	B1	C	D	E		F	G	Disc Spring Ref	X	H
						MIN	MAX					
14	19.29	5.31	2.17	7.68	3.74	1.57	2.36	M30	8.15	80 x 41 x 4	0.04	1.61
15	20.87											
16	25.39	6.57	2.56	9.96	4.92	1.97	2.95	M36	10.31	100 x 51 x 6	0.04	2.05
17	27.56											
18	33.27	8.74	3.15	12.91	5.91	2.76	4.13	M48	13.23	125 x 71 x 6	0.07	2.83
19	35.83											
21 & 22	Contact our Application Engineers											



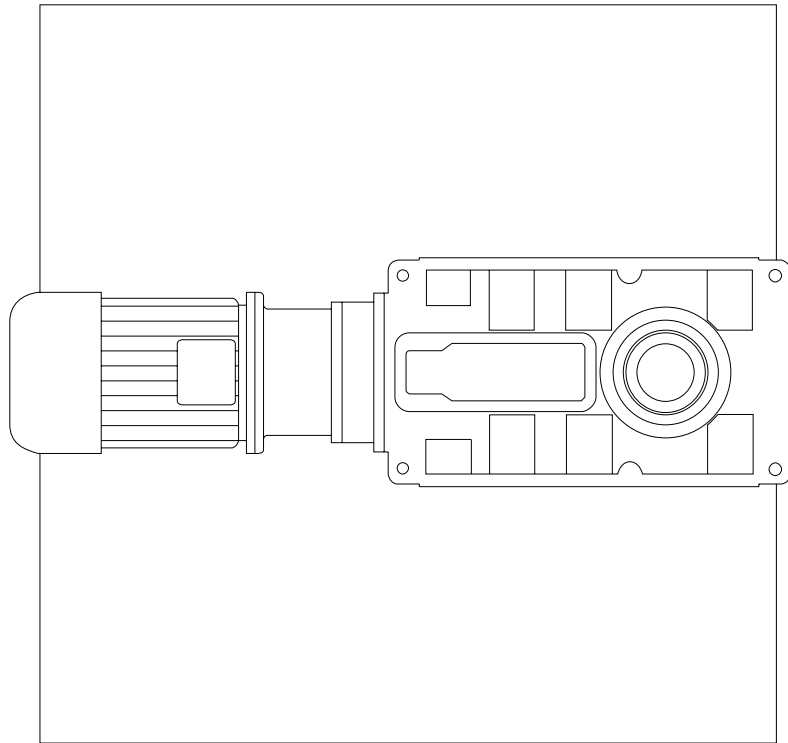

**MOTORIZED  
SERIES G**

# SERIES G

## MOTORIZED DIMENSIONS

### Parallel Shaft Units

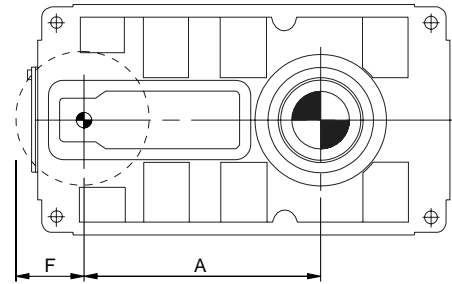
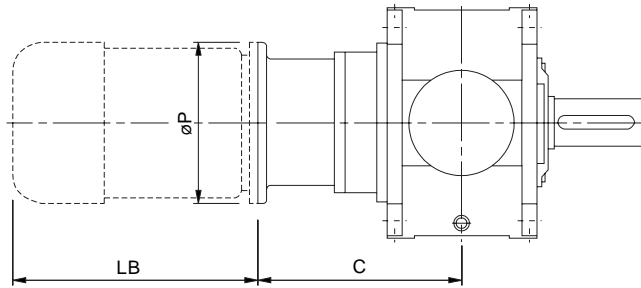

### Double Reduction

NEMA Motors						
Unit Size	Motor Size	Column 13 Entry	C	F	LB (max)	ØP
G1420	324TC/326TC	R	17.52	9.02	25.87	13.37
	364TC/365TC	S	18.15	9.02	30.91	13.37
	404TC/405TC	T	19.52	9.02	33.03	13.87
G1520	324TC/326TC	R	17.52	9.02	25.87	13.37
	364TC/365TC	S	18.15	9.02	30.91	13.37
	404TC/405TC	T	19.52	9.02	33.03	13.87
G1620	364TC/365TC	S	20.31	15.08	30.91	13.37
	404TC/405TC	T	21.69	15.08	33.03	13.87
G1720	364TC/365TC	S	20.31	15.08	30.91	13.37
	404TC/405TC	T	21.69	15.08	33.03	13.87

IEC Motors							
Unit Size	Motor Size	Column 13 Entry	A	C	F	LB (max)	ØP
G1420	200	D	12.8	16.85	9.02	25.63	15.75
	225	E	12.8	18.03	9.02	30.94	17.72
	250	F	12.8	18.03	10.83	33.03	21.65
	280	G	12.8	18.03	10.83	37.44	21.65
G1520	200	D	14.37	16.85	9.02	25.63	15.75
	225	E	14.37	18.03	9.02	30.94	17.72
	250	F	14.37	18.03	10.83	33.03	21.65
	280	G	14.37	18.03	10.83	37.44	21.65
G1620	250	F	16.93	20.2	11.73	33.03	21.65
	280	G	16.93	20.2	11.73	37.44	21.65
G1720	250	F	19.09	20.2	11.73	33.03	21.65
	280	G	19.09	20.2	11.73	37.44	21.65

### Triple and Quadruple Reduction

NEMA Motors						
Unit Size	Motor Size	Column 13 Entry	C	F	LB (max)	ØP
G1430 / G1440	254TC/256TC	P	14.69	6.69	21.50	10.00
	284TC/286TC	Q	15.32	6.69	23.82	11.25
	324TC/326TC	R	15.94	6.69	25.87	13.37
	364TC/365TC	S	16.57	6.69	30.91	13.37
	404TC/405TC	T	17.94	6.97	33.03	13.87
G1530 / G1540	254TC/256TC	P	14.69	6.69	21.50	10.00
	284TC/286TC	Q	15.32	6.69	23.82	11.25
	324TC/326TC	R	15.94	6.69	25.87	13.37
	364TC/365TC	S	16.57	6.69	30.91	13.37
	404TC/405TC	T	17.94	6.97	33.03	13.87
G1630 / G1640	254TC/256TC	P	17.25	6.69	21.50	10.00
	284TC/286TC	Q	17.88	6.69	23.82	11.25
	324TC/326TC	R	18.50	6.69	25.87	13.37
	364TC/365TC	S	19.13	6.69	30.91	13.37
	404TC/405TC	T	20.50	6.97	33.03	13.87
G1730 / G1740	254TC/256TC	P	17.25	6.69	21.50	10.00
	284TC/286TC	Q	17.88	6.69	23.82	11.25
	324TC/326TC	R	18.50	6.69	25.87	13.37
	364TC/365TC	S	19.13	6.69	30.91	13.37
	404TC/405TC	T	20.50	6.97	33.03	13.87
G1830 / G1840	254TC/256TC	P	21.19	7.80	21.50	10.00
	284TC/286TC	Q	21.81	7.80	23.82	11.25
	324TC/326TC	R	22.44	7.80	25.87	13.37
	364TC/365TC	S	23.07	7.80	30.91	13.37
	404TC/405TC	T	24.44	7.80	33.03	13.87
G1930 / G1940	254TC/256TC	P	21.19	7.80	21.50	10.00
	284TC/286TC	Q	21.81	7.80	23.82	11.25
	324TC/326TC	R	22.44	7.80	25.87	13.37
	364TC/365TC	S	23.07	7.80	30.91	13.37
	404TC/405TC	T	24.44	7.80	33.03	13.87

IEC Motors							
Unit Size	Motor Size	Column 13 Entry	A	C	F	LB (max)	ØP
G1430 / G1440	132	A	17.13	14.09	6.69	16.54	11.81
	160	B	17.13	15.28	6.89	21.26	13.78
	180	C	17.13	15.28	6.89	23.54	13.78
	200	D	17.13	15.28	7.87	25.63	15.75
	225	E	17.13	16.46	8.86	30.94	17.72
	250	F	17.13	16.46	10.83	33.03	21.65
G1530 / G1540	132	A	18.70	14.09	6.69	16.54	11.81
	160	B	18.70	15.28	6.89	21.26	13.78
	180	C	18.70	15.28	6.89	23.54	13.78
	200	D	18.70	15.28	7.87	25.63	15.75
	225	E	18.70	16.46	8.86	30.94	17.72
	250	F	18.70	16.46	10.83	33.03	21.65
G1630 / G1640	132	A	22.44	16.65	6.69	16.54	11.81
	160	B	22.44	17.83	6.89	21.26	13.78
	180	C	22.44	17.83	6.89	23.54	13.78
	200	D	22.44	17.83	7.87	25.63	15.75
	225	E	22.44	19.02	8.86	30.94	17.72
	250	F	22.44	19.02	10.83	33.03	21.65
	280	G	22.44	19.02	10.83	37.44	21.65
G1730 / G1740	132	A	24.61	16.65	6.69	16.54	11.81
	160	B	24.61	17.83	6.89	21.26	13.78
	180	C	24.61	17.83	6.89	23.54	13.78
	200	D	24.61	17.83	7.87	25.63	15.75
	225	E	24.61	19.02	8.86	30.94	17.72
	250	F	24.61	19.02	10.83	33.03	21.65
	280	G	24.61	19.02	10.83	37.44	21.65
G1830 / G1840	180	C	29.72	21.77	7.80	23.54	13.78
	200	D	29.72	21.77	7.87	25.63	15.75
	225	E	29.72	22.95	8.86	30.94	17.72
	250	F	29.72	22.95	10.83	33.03	21.65
	280	G	29.72	22.95	10.83	37.44	21.65
G1930 / G1940	180	C	32.28	21.77	7.80	23.54	13.78
	200	D	32.28	21.77	7.87	25.63	15.75
	225	E	32.28	22.95	8.86	30.94	17.72
	250	F	32.28	22.95	10.83	33.03	21.65
	280	G	32.28	22.95	10.83	37.44	21.65

# SERIES G

## MOTORIZED DIMENSIONS

### Right Angle Shaft Units

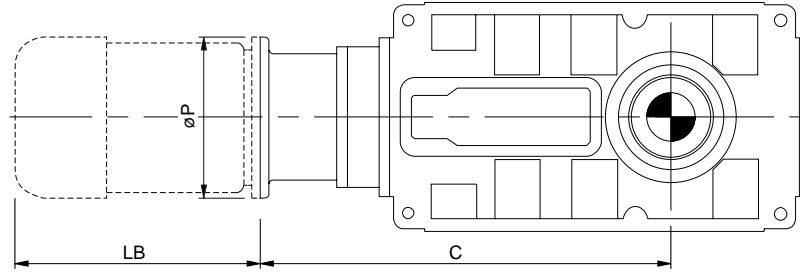

### Triple Reduction

NEMA Motors					
Unit Size	Motor Size	Column 13 Entry	C	LB (max)	ØP
G1430	254TC/256TC	P	32.22	21.50	10.00
	284TC/286TC	Q	32.84	23.82	11.25
	324TC/326TC	R	33.46	25.87	13.37
	364TC/365TC	S	34.09	30.91	13.37
	404TC/405TC	T	35.46	33.03	13.87
G1530	254TC/256TC	P	33.79	21.50	10.00
	284TC/286TC	Q	34.41	23.82	11.25
	324TC/326TC	R	35.04	25.87	13.37
	364TC/365TC	S	35.67	30.91	13.37
	404TC/405TC	T	37.04	33.03	13.87
G1630	324TC/326TC	R	42.13	25.87	13.37
	364TC/365TC	S	42.75	30.91	13.37
	404TC/405TC	T	44.13	33.03	13.87
G1730	324TC/326TC	R	44.33	25.87	13.37
	364TC/365TC	S	44.92	30.91	13.37
	404TC/405TC	T	46.29	33.03	13.87
G1830	364TC/365TC	S	53.78	30.91	13.37
	404TC/405TC	T	55.15	33.03	13.87
G1930	364TC/365TC	S	56.33	30.91	13.37
	404TC/405TC	T	57.71	33.03	13.87

IEC Motors					
Unit Size	Motor Size	Column 13 Entry	C	LB (max)	ØP
G1430	132	A	31.61	16.54	11.81
	160	B	32.80	21.26	13.78
	180	C	32.80	23.54	13.78
	200	D	32.80	25.63	15.75
	225	E	33.98	30.94	17.72
	250	F	33.98	33.03	21.65
	280	G	33.98	37.44	21.65
G1530	132	A	33.19	16.54	11.81
	160	B	34.37	21.26	13.78
	180	C	34.37	23.54	13.78
	200	D	34.37	25.63	15.75
	225	E	35.55	30.94	17.72
	250	F	35.55	33.03	21.65
	280	G	35.55	37.44	21.65
G1630	200	D	41.46	25.63	15.75
	225	E	42.64	30.94	17.72
	250	F	42.64	33.03	21.65
	280	G	42.64	37.44	21.65
G1730	200	D	43.62	25.63	15.75
	225	E	44.80	30.94	17.72
	250	F	44.80	33.03	21.65
	280	G	44.80	37.44	21.65
G1830	225	E	53.66	30.94	17.72
	250	F	53.66	33.03	21.65
	280	G	53.66	37.44	21.65
G1930	225	E	56.22	30.94	17.72
	250	F	56.22	33.03	21.65
	280	G	56.22	37.44	21.65

### Quadruple Reduction

NEMA Motors					
Unit Size	Motor Size	Column 13 Entry	C	LB (max)	ØP
G1640	254TC/256TC	P	41.86	21.50	10.00
	284TC/286TC	Q	42.48	23.82	11.25
	324TC/326TC	R	43.11	25.87	13.37
	364TC/365TC	S	43.74	30.91	13.37
	404TC/405TC	T	45.11	33.03	13.87
G1740	254TC/256TC	P	44.03	21.50	10.00
	284TC/286TC	Q	44.65	23.82	11.25
	324TC/326TC	R	45.28	25.87	13.37
	364TC/365TC	S	45.90	30.91	13.37
	404TC/405TC	T	47.28	33.03	13.87
G1840	254TC/256TC	P	53.67	21.50	10.00
	284TC/286TC	Q	54.30	23.82	11.25
	324TC/326TC	R	54.96	25.87	13.37
	364TC/365TC	S	55.55	30.91	13.37
	404TC/405TC	T	56.92	33.03	13.87
G1940	254TC/256TC	P	56.25	21.50	10.00
	284TC/286TC	Q	56.85	23.82	11.25
	324TC/326TC	R	57.52	25.87	13.37
	364TC/365TC	S	58.11	30.91	13.37
	404TC/405TC	T	59.48	33.03	13.87

IEC Motors					
Unit Size	Motor Size	Column 13 Entry	C	LB (max)	ØP
G1640	132	A	41.26	16.54	11.81
	160	B	42.44	21.26	13.78
	180	C	42.44	23.54	13.78
	200	D	42.44	25.63	15.75
	225	E	43.62	30.94	17.72
	250	F	43.62	33.03	21.65
G1740	132	A	43.82	16.54	11.81
	160	B	44.61	21.26	13.78
	180	C	44.61	23.54	13.78
	200	D	44.61	25.63	15.75
	225	E	45.79	30.94	17.72
	250	F	45.79	33.03	21.65
G1840	160	B	54.25	21.26	13.78
	180	C	54.25	23.54	13.78
	200	D	54.25	25.63	15.75
	225	E	55.43	30.94	17.72
	250	F	55.43	33.03	21.65
	280	G	55.43	37.44	21.65
G1940	160	B	56.81	21.26	13.78
	180	C	56.81	23.54	13.78
	200	D	56.81	25.63	15.75
	225	E	57.99	30.94	17.72
	250	F	57.99	33.03	21.65
	280	G	57.99	37.44	21.65

# SERIES G

## SHIPPING SPECIFICATIONS

### UNIT MASS (lb's)

Gear Unit	No of Reductions	Output Shaft	Unit Size							
			14	15	16	17	18	19	21	22
Parallel Shaft	2 Stage	Standard	794	915	1743	1996	3375	4136	6949	8030
		Shaft Mount	750	849	1666	1886	3166	3872	6508	7430
		Agitator	882	1004	1853	2162	3596	4401	7390	-
	3 Stage	Standard	827	949	1776	2030	3419	4180	7059	8140
		Shaft Mount	783	882	1699	1919	3210	3916	6618	7540
		Agitator	915	1037	1886	2195	3640	4445	7500	-
	4 Stage	Standard	849	971	1809	2063	3485	4247	7170	8250
		Shaft Mount	805	893	1732	1952	3276	3982	6728	7650
		Agitator	938	1059	1919	2228	3706	4511	7611	-
Right Angle Shaft	3 Stage	Standard	871	993	1853	2074	3618	4379	7390	8471
		Shaft Mount	827	927	1775	1963	3408	4114	6949	7870
		Agitator	960	1081	1963	2239	3838	4644	7831	-
	4 Stage	Standard	-	-	1853	2074	3574	4335	7280	8361
		Shaft Mount	-	-	1775	1555	3364	4070	6839	7760
		Agitator	-	-	1963	1963	3794	4600	7721	-

Mass excludes: lubricant, cooling fans or coil.

### UNIT VOLUME (Feet <sup>3</sup>)

Gear Unit	No of Reductions	Output Shaft	Unit Size							
			14	15	16	17	18	19	21	22
Parallel Shaft	2 Stage	Standard	9.7	9.9	20.4	20.9	39.6	45.8	73.5	78.0
		Shaft Mount	7.1	7.1	14.8	14.8	28.6	31.6	62.2	65.0
		Agitator	10.9	11.2	22.5	22.9	43.5	50.2	83.0	-
	3 Stage	Standard	9.1	9.3	19.7	20.2	38.2	44.1	72.7	78
		Shaft Mount	6.5	6.5	14.0	14.0	27.2	30.0	60.7	63.60
		Agitator	10.3	10.6	21.8	22.2	42.1	48.6	81.9	-
	4 Stage	Standard	9.1	9.3	19.7	20.2	38.2	44.1	72.7	76.60
		Shaft Mount	6.5	6.5	14.0	14.0	27.2	30.0	60.7	63.6
		Agitator	10.3	10.6	21.8	22.2	42.1	48.6	81.9	-
Right Angle Shaft	3 Stage	Standard	9.3	9.4	20.1	20.7	39.4	45.2	74.9	77.0
		Shaft Mount	7.5	7.6	16.3	16.7	31.4	35.1	61.1	64.0
		Agitator	10.7	11.1	22.8	23.3	44.5	50.9	51.9	-
	4 Stage	Standard	-	-	20.5	21.1	40.5	46.4	75.9	78.0
		Shaft Mount	-	-	16.6	17.1	32.3	36.1	62.2	65.0
		Agitator	-	-	23.2	23.8	45.8	52.2	88.3	-

## IMPORTANT

### Product Safety Information

**General** - The following information is important in ensuring safety. It **must** be brought to the attention of personnel involved in the selection of the equipment, those responsible for the design of the machinery in which it is to be incorporated and those involved in its installation, use and maintenance.

The equipment will operate safely provided it is selected, installed, used and maintained properly. As with any power transmission equipment **proper precautions must** be taken as indicated in the following paragraphs, to ensure safety.

**Potential Hazards** - these are **not** necessarily listed in any order of severity as the degree of danger varies in individual circumstances. It is important therefore that the list is studied in its entirety:-

- 1) Fire/Explosion
  - (a) Oil mists and vapour are generated within gear units. It is therefore dangerous to use naked lights in the proximity of gearbox openings, due to the risk of fire or explosion.
  - (b) In the event of fire or serious overheating (over 300 °C), certain materials (rubber, plastics, etc.) may decompose and produce fumes. Care should be taken to avoid exposure to the fumes, and the remains of burned or overheated plastic/rubber materials should be handled with rubber gloves.
- 2) Guards - Rotating shafts and couplings must be guarded to eliminate the possibility of physical contact or entanglement of clothing. It should be of rigid construction and firmly secured.
- 3) Noise - High speed gearboxes and gearbox driven machinery may produce noise levels which are damaging to the hearing with prolonged exposure. Ear defenders should be provided for personnel in these circumstances. Reference should be made to the Department of Employment Code of Practice for reducing exposure of employed persons to noise.
- 4) Lifting - Where provided (on larger units) only the lifting points or eyebolts must be used for lifting operations (see maintenance manual or general arrangement drawing for lifting point positions). Failure to use the lifting points provided may result in personal injury and/or damage to the product or surrounding equipment. Keep clear of raised equipment.
- 5) Lubricants and Lubrication
  - (a) Prolonged contact with lubricants can be detrimental to the skin. The manufacturer's instruction must be followed when handling lubricants.
  - (b) The lubrication status of the equipment must be checked before commissioning. Read and carry out all instructions on the lubricant plate and in the installation and maintenance literature. Heed all warning tags. Failure to do so could result in mechanical damage and in extreme cases risk of injury to personnel.
- 6) Electrical Equipment - Observe hazard warnings on electrical equipment and isolate power before working on the gearbox or associated equipment, in order to prevent the machinery being started.
- 7) Installation, Maintenance and Storage
  - (a) In the event that equipment is to be held in storage, for a period exceeding 6 months, prior to installation or commissioning, application engineering must be consulted regarding special preservation requirements. Unless otherwise agreed, equipment must be stored in a building protected from extremes of temperature and humidity to prevent deterioration.  
  
The rotating components (gears and shafts) must be turned a few revolutions once a month (to prevent bearings brinelling).
  - (b) External gearbox components may be supplied with preservative materials applied, in the form of a "waxed" tape overwrap or wax film preservative. Gloves should be worn when removing these materials. The former can be removed manually, the latter using white spirit as a solvent.  
  
Preservatives applied to the internal parts of the gear units do not require removal prior to operation.
  - (c) Installation must be performed in accordance with the manufacturer's instructions and be undertaken by suitably qualified personnel.
  - (d) Before working on a gearbox or associated equipment, ensure that the load has been removed from the system to eliminate the possibility of any movement of the machinery and isolate power supply. Where necessary, provide mechanical means to ensure the machinery cannot move or rotate. Ensure removal of such devices after work is complete.
  - (e) Ensure the proper maintenance of gearboxes in operation. Use only the correct tools and approved spare parts for repair and maintenance. Consult the Maintenance Manual before dismantling or performing maintenance work.
- 8) Hot Surfaces and Lubricants
  - (a) During operation, gear units may become sufficiently hot to cause skin burns. Care must be taken to avoid accidental contact.
  - (b) After extended running the lubricant in gear units and lubrication systems may reach temperatures sufficient to cause burns. Allow equipment to cool before servicing or performing adjustments.
- 9) Selection and Design
  - (a) Where gear units provide a backstop facility, ensure that back-up systems are provided if failure of the backstop device would endanger personnel or result in damage.
  - (b) The driving and driven equipment must be correctly selected to ensure that the complete machinery installation will perform satisfactorily, avoiding system critical speeds, system torsional vibration, etc.
  - (c) The equipment must not be operated in an environment or at speeds, powers, torques or with external loads beyond those for which it was designed.
  - (d) As improvements in design are being made continually the contents of this Catalog are not to be regarded as binding in detail, and drawings and capacities are subject to alterations without notice.

The above guidance is based on the current state of knowledge and our best assessment of the potential hazards in the operation of the gear units.

Any further information or clarification required may be obtained by contacting an Application Engineer.



# CONTACT US

## AUSTRALIA

**Radicon Transmission  
(Australia) PTY Ltd**  
Australia

Tel: +61 488 054 028

## EUROPE

**Benzler TBA BV**  
Jachthavenweg 2  
NL-5928 NT Venlo

Austria  
Tel: +43 7 229 618 91  
Fax: +43 7 229 618 84

France  
Tel: +33 687 718 711  
Fax: +31 77 324 59 01

Germany  
Tel: 0800 350 40 00  
Fax: 0800 350 40 01

Italy  
Tel: +39 02 824 3511

Netherlands & the rest of Europe  
Tel: +31 77 324 59 00  
Fax: +31 77 324 59 01

## DENMARK

**Benzler Transmission A/S**  
Fuglebævej 3D  
DK-2770 Kastrup,  
Denmark

Tel: +45 36 34 03 00  
Fax: +45 36 77 02 42

## FINLAND

**Oy Benzler AB**  
Vanha Talvitie 3C  
FI-00580 Helsingfors,  
Finland

Tel: +358 9 340 1716  
Fax: +358 10 296 2072

## INDIA

**Elecon. Engineering  
Company Ltd.**  
Anand Sojitra Road  
Vallabh Vidyanagar  
388120 Gujarat  
India

Tel: +91 2692 236513  
Fax: +91 2692 227484

## SWEDEN & NORWAY

**AB Benzlers**  
Box 922 (Landskronavägen 1)  
251 09 Helsingborg  
Sweden

Tel: +46 42 18 68 00  
Fax: +46 42 21 88 03

## THAILAND

**Radicon Transmission  
(Thailand) Ltd**  
700/43 Moo 6  
Amata Nakorn Industrial Estate  
Tumbol Klontumru  
Muang,  
Chonburi  
20000  
Thailand

Tel: +66 3845 9044  
Fax: +66 3821 3655

## UNITED KINGDOM

**Radicon Transmission UK Ltd**  
Unit J3  
Lowfields Business Park,  
Lowfields Way, Elland  
West Yorkshire, HX5 9DA

Tel: +44 (0) 1484 465 800  
Fax: +44 (0) 1484 465 801

## USA

**Radicon USA Transmission Ltd**  
1599 Lunt Avenue  
Elk Grove Village  
Chicago  
Illinois  
60007  
USA

Tel: +1 847 593 9910  
Fax: +1 847 593 9950

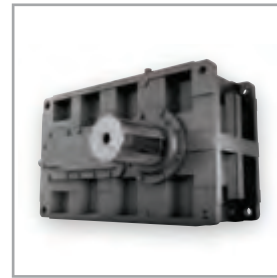
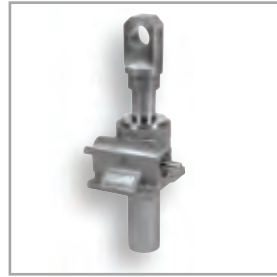

radicon 

**Radicon USA**  
1599 Lunt Avenue, Elk Grove Village, IL 60007  
Phone: +1 847 593 9910  
Email: SalesUSA@radicon.com  
[www.radicon.com](http://www.radicon.com)